



## SAKARYA GAS FIELD DEVELOPMENT PROJECT

CONTRACT NO: SC26-PRJ-PU-CNT-00179

### ENVIRONMENTAL AND SOCIAL IMPACT ASSESSMENT (ESIA)

*Chapter 1 - Introduction; Chapter 2 - Regulatory Framework; Chapter 3 - Project Description*

COMPANY Doc. No. SC26-OTC-PRJ-EN-REP-000005



CONTRACTOR Project No. 214970791

05	28/09/2022	Issued for Approval	Gülçin Kadioğlu	Beyza Kozak	Giovanni Torchia	
04	08/09/2022	Issued for Review	Gülçin Kadioğlu	Beyza Kozak	Giovanni Torchia	
03	12/08/2022	Issued for Review	Gülçin Kadioğlu	Beyza Kozak	Giovanni Torchia	
02	04/07/2022	Issued for Review	Gülçin Kadioğlu	Beyza Kozak	Giovanni Torchia	
01	14/04/2022	Issued for Review	Gülçin Kadioğlu	Beyza Kozak	Giovanni Torchia	
00	11/03/2022	Issued for Review	Gülçin Kadioğlu	Beyza Kozak	Giovanni Torchia	
Rev. N°	Date	Issue Type	Prepared by	Checked by	Approved by	COMPANY Acceptance Code
					Classification:	Internal

REVISION TRACKING TABLE		
Rev. N°	Modification Description	Modified Page No.
00	Issued for review	N/A
01	Issued for review	Entire document
02	Issued for review	Entire document
03	Issued for review	Entire document
04	Issued for review – Equipment list updated	Chapter 3.7.2 Table 16
05	Issued for approval	N/A

### Information Classification

Code	Description of Information Classification
PUBLIC	Information and data that may be shared without restrictions because it is unlikely to result in any harm if disclosed to outside parties. Permission to actually release information to the public must be obtained separately through External Affairs
INTERNAL	Information and data that may be freely shared with staff in Engineer, Client and Partners, and contracted companies and individuals bounded by confidentiality agreements.
RESTRICTED	Only 5-10% of document content with such information classification can be released by Document Owner (or with his delegation) to identified recipients.
CONFIDENTIAL	Information that is extremely sensitive, of the highest value to the company and individuals and intended for use by named individual(s) only.

## Study Limitations

This report has been prepared based on the written and verbal information and documentation provided to Golder as of the date of this Environmental and Social Impact Assessment (ESIA) Report by the Turkish Petroleum Offshore Technology Center (TP-OTC or the “Client” or “Project Owner”). Golder cannot confirm the accuracy of the information provided by third parties during ESIA process. This version of ESIA has not yet been approved by the lenders and ESDD consultant. Additional revisions are possible.

**IMPORTANT:** This section should be read before reliance is placed on any of the opinions, advice, recommendations, or conclusions herein set out.

- a) The purpose of this report was to undertake an Environmental and Social Impact Assessment pursuant to the appointment of Golder to act as Consultant for the Sakarya Gas Field Development Project.
- b) Except for the Project Owner and the Lenders, any use which a third party makes of this report, or any reliance on or decisions to be made based on it, are the responsibility of the third parties. Should additional parties require reliance on this report, written authorisation from Golder will be required. Golder disclaims responsibility of consequential financial effects on transactions or property values, or requirements for follow-up actions and costs. No duty is undertaken, nor warranty nor representation made to any party in respect of the opinions, advice, recommendations or conclusions herein set out.
- c) The Project description included in this report is based on data and information provided to Golder by the Project Owner. It is based solely on a review of information and data obtained from the Project Owner as described in this report, and discussion with representatives of TP-OTC, as reported herein. Except as otherwise may be requested, Golder disclaims any obligation to update this report for events taking place, or with respect to information that becomes available to Golder after the time during which Golder conducted the ESIA.
- d) Project design is currently being evaluated by TP-OTC and its Contractors and changes have occurred during the preparation of this report and are expected until design is finalized. This ESIA report is based on the design information made available to Golder as of the date of this report.
- e) No soil, water, liquid, gas, product, exposure, Occupational Health and Safety (OHS), chemical sampling or analytical testing at or in the vicinity of the Project was conducted by Golder, as part of this ESIA study.
- f) In evaluating the Project, Golder has relied in good faith on information provided by other entities noted in this report. Golder has assumed that the information provided is factual and accurate. In addition, the findings in this report are based, to a large degree, upon information provided by the Investor. Golder accepts no responsibility for any deficiency, misstatement or inaccuracy contained in this report as a result of omissions, misinterpretations or fraudulent acts of persons interviewed or contacted.
- g) Golder makes no other representations whatsoever, including those concerning the legal significance of its findings, or as to other legal matters touched on in this report, including, but not limited to, ownership of any property, or the application of any law to the facts set forth herein. With respect to regulatory compliance issues, regulatory statutes are subject to interpretation. These interpretations may change over time; thus, the client should review these issues with appropriate legal counsel.

Title:	<i>Chapter 1 - Introduction; Chapter 2 - Regulatory Framework; Chapter 3 - Project Description</i>	Classification:	Internal
DocID:	SC26-OTC-PRJ-EN-REP-000005	Page:	3 of 133
Rev. :	05		

# Table of Contents

<b>1.0 INTRODUCTION .....</b>	<b>22</b>
1.1 Background on the Gas Field .....	25
1.2 Background on the Applicant, TPAO/TP-OTC.....	25
1.3 Purpose of the ESIA Report.....	26
1.3.1 Objectives .....	26
1.3.2 Categorization of the Project .....	27
1.3.3 Steps of the ESIA.....	28
1.3.3.1 Gap Analysis.....	28
1.3.3.2 Review of Additional Documentation.....	28
1.3.3.3 Baseline Data Collection.....	28
1.3.3.4 Stakeholder Engagement .....	28
1.3.3.5 Impact Assessment and Mitigation Measures .....	29
1.4 Uncertainties .....	29
1.5 Environmental and Social Management and Monitoring .....	30
1.6 Outline of the ESIA Report.....	30
<b>2.0 REGULATORY AND POLICY FRAMEWORK.....</b>	<b>31</b>
2.1 Applicable Turkish Legislation .....	31
2.1.1 Labour and H&S Regulations .....	31
2.1.2 Permitting Framework.....	32
2.2 Applicable International Legislation .....	35
2.3 Equator Principles, IFC Performance Standards, and WBG EHS Guidelines.....	38
2.3.1 Equator Principles IV (2020).....	38
2.3.2 IFC Performance Standards (2012).....	39
2.3.2.1 IFC General EHS Guidelines.....	39
2.3.2.2 IFC EHS Guidelines for Onshore Oil and Gas Development .....	40
2.3.2.3 IFC EHS Guidelines for Offshore Oil and Gas Development .....	40
2.3.2.4 IFC EHS Guidelines for Electric Power Transmission and Distribution .....	41
2.3.2.5 IFC EHS Guidelines for Shipping .....	41

2.3.2.6	Performance Indicators and Monitoring, Documents Pertaining to Human Rights .....	42
2.3.2.7	Other IFC Guidelines .....	42
2.3.3	Environmental Limits.....	43
<b>3.0</b>	<b>PROJECT DESCRIPTION .....</b>	<b>44</b>
3.1	Project Overview and Schedule .....	44
3.1.1	Project Description .....	44
3.1.1.1	Project Components .....	44
3.1.1.2	Project Associated Facilities .....	47
3.1.1.3	Other Facilities .....	48
3.1.2	Project Rationale.....	50
3.1.3	Project Parties.....	53
3.1.4	Project Schedule.....	54
3.1.5	Project Location and Land Ownership.....	55
3.1.6	Labor and Working Conditions .....	60
3.2	Subsea Production System (SPS) .....	61
3.2.1	General Description .....	61
3.2.2	Construction Phase.....	62
3.2.3	Operation Phase .....	64
3.3	SURF.....	65
3.3.1	General Description .....	65
3.3.2	Construction Phase.....	65
3.3.3	Operation Phase .....	75
3.4	Onshore Production Facility (OPF) .....	76
3.4.1	General Description .....	76
3.4.2	Construction Phase.....	77
3.4.3	Operation Phase .....	83
3.5	Transformer Station and Energy Transmission Line .....	98
3.5.1	General Description .....	98
3.5.2	Construction phase .....	98

3.5.3	Operation phase .....	100
3.6	Construction Camp Sites & Permanent Lodgings .....	100
3.7	Resource and Infrastructure Requirements .....	105
3.7.1	General .....	105
3.7.2	Construction Phase.....	106
3.7.2.1	Materials .....	106
3.7.2.2	Vessels .....	107
3.7.2.3	Onshore Equipment.....	110
3.7.2.4	Infrastructure.....	112
3.7.3	Operation Phase .....	119
3.7.3.1	Materials .....	119
3.7.3.2	Vessels .....	120
3.7.3.3	Onshore Equipment.....	120
3.7.3.4	Infrastructure.....	120
3.8	Emission, Wastewater and Waste .....	122
3.8.1	Construction Phase.....	122
3.8.2	Operation Phase .....	127
3.9	Field Life and Decommissioning .....	131

**TABLES**

Table 2-1: The Main Permits and Approvals Required .....32

Table 3-1: Total Natural Gas Consumption Amounts in Turkey by Years (Million Sm3) .....51

Table 3-2: Project Main Contractors and Scope of Works .....54

Table 3-3: Employee Numbers as of September 2022 .....60

Table 3-4: Outer Inspection Operations .....76

Table 3-5: Other Inspection Operations .....76

Table 3-6: The Properties of the Gas to be Transported Through Pipeline (BOTAŞ Limits) .....86

Table 3-7: Chemical Injection Requirements .....90

Table 3-8: Waste Management Facilities in Zonguldak .....105

Table 3-9: Urban wastewater Management Facilities in Zonguldak .....105

Table 3-10: Offshore Section Construction Materials and Estimated Quantities .....106

Table 3-11: Onshore Section Construction Materials and Estimated Quantities .....106

Table 3-12: The Vessels to be Utilized During Construction Phase of Offshore and Coastal Crossing Sections .....107

Table 3-13: Fuel Consumption Calculations of the Vessels to be used during Construction .....109

Table 3-14: Equipment List (June 2022) .....110

Table 3-15: Water Consumption Data for the Vessels to be used in the Offshore Section during the Construction Phase .....113

Table 3-16: Indicative Water Use During Construction Phase .....116

Table 3-18: Discharges related with Pre-commissioning Activities of SPS and SURF .....123

Table 3-19: Wastewater to be Generated During the Construction Phase and Management Methods .....125

Table 3-20: Wastewater to be Generated During the Operation Phase and Management Methods .....129

**FIGURES**

Figure 1-1: Sakarya Gas Field Development Project, BOTAŞ FMS and Pipeline Layout .....24

Figure 1-2: Relation of TPAO and TP-OTC with the Project .....26

Figure 1-3: Steps of Golder's Impact Assessment methodology .....29

Figure 3-1: Illustration of Main Project Units.....45

Figure 3-2: Project Renders .....46

Figure 3-3: Aerial View of Water Winning Spread at CLC.....49

Figure 3-4: Global Primary Energy Consumption Rates in 2019 .....50

Figure 3-5: 2020 Natural Gas Sectoral Consumption Distribution in Turkey (%) .....52

Figure 3-6: Share of Imported Natural Gas by Source Country in 2020 .....52

Figure 3-7: Provisional Project Schedule \*TA: Türkali Well .....55

Figure 3-8: Nearest Settlements Map.....56

Figure 3-9: Previous and Current Land Status of the Filyos Industrial Zone and TPAO Special Investment Zone .....58

Figure 3-10: Site Location Map .....59

Figure 3-11: Illustration of Subsea Production System .....62

Figure 3-12: The Flow Process Chart of The Subsea Production System (Source: EIA Report) .....65

Figure 3-13: Dredging Stages .....66

Figure 3-14: Overview of Coastal and Coastal Crossing Section Routes .....67

Figure 3-15: Coastal Crossing Profile - Schematic Trench Width (KP 0 – KP 0+268 (water depth 0-3 m)) .....68

Figure 3-16: Coastal Crossing Profile - Schematic Trench Width (Trench Transition Zone at KP 1+344) .....68

Figure 3-17: Satellite Image Showing the Temporary Dumping Area .....69

Figure 3-18: A Typical Cofferdam (Source: EIA Report) .....70

Figure 3-19: Backfill Process .....71

Figure 3-20: Typical Images of Vessels to Be Used at Near Shore Dredging .....72

Figure 3-21: Pig Train Configuration for Gas Trunkline During Nitrogen Dewatering .....74

Figure 3-22: Pig Train Configuration for MEG First Fill .....75

Figure 3-23: OPF Planning .....77

Figure 3-24: Generalized Process Diagram of the Concrete Batching Plant .....79

Figure 3-25: Workflow Chart of the OPF .....83

Figure 3-26: Workflow Chart of the OPF, Low pressure .....84

Figure 3-27: Workflow Chart of The MEG Pre-Treatment Unit and MEG Regeneration and Reclamation Unit 89

Figure 3-28: Project Layout .....97

Figure 3-29: Satellite Image Showing Access Roads (Red) of Energy Transmission Line (Blue) .....99

Figure 3-30: Typical Image of Poles .....99

Figure 3-31: Construction Camps Positions .....102

Figure 3-32: Schlumberger Camp&Offices Layout.....104

Figure 3-33: Access Roads - Construction.....118

Figure 3-34: Access and Connection Roads – Construction.....119



## **APPENDICES**

**APPENDIX A** - BOTAS High-Level E&S Report

**APPENDIX B** - List of Applicable National Legislation and International Agreements Ratified by Turkey

**APPENDIX C** - Applicable Environmental Limits

**APPENDIX D** - Detailed Project Schedule

**APPENDIX E** - Meteorology

**APPENDIX F** - Flora Report

**APPENDIX G** - Hydrobiological Studies of Yenice River

**APPENDIX H** - Terrestrial Fauna Biodiversity Study

**APPENDIX I** - eDNA Project qPCR Report

**APPENDIX J** - Preliminary Allocation Letter

**APPENDIX K** - Impact Matrices

**APPENDIX L** - Flood Risk Analysis

**APPENDIX M** - Biodiversity Action Plan

**Appendix N** - Preliminary Mitigation Measures For The Construction Activities Of The Energy Transmission Line

**Appendix O** - Preliminary Mitigation Measures For The Construction Activities In Proximity Of the Coastal Lake/Pond And Yenice River Area

**Appendix P** - Noise & Vibration Report

## DEFINITIONS

<b>COMPANY</b>	Turkish Petroleum - Offshore Technology Center A.S. (TP-OTC)
<b>CONSULTANT</b>	WSP Golder Associates Turkey Ltd. Şti. (GOLDER)
<b>PROJECT</b>	Sakarya Gas Field Development (SGFD) Project (Unless otherwise stated, SGFD Project refers to the Phase 1 of the investment. SGFD Phase 1 is the topic of this ESIA)
<b>PROJECT OWNER</b>	TPAO
<b>PROJECT EXECUTOR</b>	TP-OTC

## ABBREVIATIONS

Abbreviation	Definition
<b>ACCOBAMS</b>	Agreement on the Conservation of Cetaceans of the Black Sea, Mediterranean Sea and Contiguous Atlantic Area
<b>ADCP</b>	Acoustic Doppler Current Profiler
<b>AF</b>	Associated Facility
<b>AFAD</b>	Disaster and Emergency Management Presidency of Turkey
<b>ALARP</b>	As Low As Reasonably Possible
<b>AoI</b>	Area of Influence
<b>AOX</b>	Adsorbable Organic Halides
<b>AR4</b>	Fourth Assessment Report
<b>AR5</b>	Fifth Assessment Report
<b>AR6</b>	Sixth Assessment Report
<b>ASTM</b>	American Society for Testing and Materials
<b>BAP</b>	Biodiversity Action Plan
<b>BAU</b>	Business As Usual
<b>Barg</b>	Bar gauge
<b>BCM</b>	Billion cubic meter
<b>BERN</b>	Convention on the Conservation of European Wildlife and Natural Habitats

Abbreviation	Definition
<b>BMP</b>	Biodiversity Management Plan
<b>BOD</b>	Biological Oxygen Demand
<b>BOTAŞ</b>	Turkish Petroleum Pipeline Corporation
<b>BTEX</b>	Benzene, Toluene, Ethylbenzene, Xylene
<b>CAPEX</b>	Capital Expenditure
<b>CBAM</b>	Carbon Border Adjustment Mechanism
<b>CCRA</b>	Climate Change Risk Assessment
<b>CEFAS</b>	The Centre for Environment, Fisheries and Aquaculture Science
<b>CFC</b>	Chlorofluorocarbon
<b>CH<sub>4</sub></b>	Methane
<b>CHS</b>	Community Health and Safety
<b>CIA</b>	Cumulative Impact Assessment
<b>CITES</b>	Convention on International Trade in Endangered Species of Wild Fauna and Flora
<b>CLC</b>	Coastal Logistics Center
<b>CLO</b>	Community Liaison Officer
<b>CLS</b>	Community Level Survey
<b>CNG</b>	Compressed Natural Gas
<b>CO</b>	Carbon Monoxide
<b>CO<sub>2</sub></b>	Carbon Dioxide
<b>CO<sub>2e</sub></b>	Carbon Dioxide Equivalent
<b>COD</b>	Chemical Oxygen Demand
<b>COP</b>	Conference of Parties
<b>CR</b>	Critically Endangered
<b>CTD</b>	Conductivity, Temperature, Depth
<b>dB</b>	Decibels
<b>DD</b>	Data Deficient

Abbreviation	Definition
<b>DO</b>	Dissolved Oxygen
<b>DSI</b>	State Hydraulic Works
<b>EC</b>	Electrical Conductivity
<b>ECA</b>	Export Credit Agency
<b>EDG</b>	Emergency Diesel Generator
<b>EF</b>	Emission Factor
<b>EHS</b>	Environmental Health and Safety
<b>EHSS</b>	Environment, Health and Safety; Social
<b>EIA</b>	Environmental Impact Assessment
<b>EN</b>	English
<b>EN</b>	Endangered (Biodiversity)
<b>EP</b>	Equator Principles
<b>EPA</b>	Environmental Protection Agency
<b>EPCI</b>	Engineering, Procurement, Construction and Installation
<b>EPFI</b>	Equator Principles Financial Institutions
<b>EPRP</b>	Emergency Preparedness and Response Plan
<b>ETL</b>	Energy Transmission Line
<b>E&amp;S</b>	Environmental and Social
<b>ESE</b>	East-Southeast
<b>ESS</b>	Environmental and Social Standards
<b>ESHS</b>	Environmental, Social, Health and Safety
<b>ESIA</b>	Environmental and Social Impact Assessment
<b>ESMP</b>	Environmental and Social Management Plan
<b>ESMS</b>	Environmental and Social Management System
<b>ETP-A</b>	Effluent Treatment Package
<b>ETP-B</b>	Sanitary Sewage Treatment System

Abbreviation	Definition
<b>EU</b>	European Union
<b>FCG-H</b>	Flooding, Cleaning, Gauging and Hydrotesting
<b>FEED</b>	Front-End Engineering Development
<b>FGD</b>	Focus Group Discussion
<b>FGR</b>	Flare Gas Recovery
<b>FI</b>	Financial Intermediaries
<b>FMS</b>	Fiscal Metering Station
<b>F/O</b>	Fuel Oil
<b>g</b>	Grams
<b>GDP</b>	Gross Domestic Product
<b>GHG</b>	Greenhouse Gas
<b>GIIP</b>	Good International Industry Practice
<b>GIS</b>	Geographic Information System
<b>GLC</b>	Ground Level Concentration
<b>GN</b>	Guidance Note
<b>Golder</b>	Golder Associates Turkey Ltd.
<b>Gpm</b>	Gallons per minute
<b>GRM</b>	Grievance Mechanism
<b>GTG</b>	Gas Turbine Generator
<b>Güngör Elektrik</b>	Güngör Electric Industry and Trade. Ltd. Sti.
<b>GWP</b>	Global Warming Potential
<b>HAZID</b>	Hazard Identification
<b>HAZOP</b>	Hazard and Operability
<b>HDD</b>	Horizontal Direction Drilling
<b>HHS</b>	Household Survey
<b>HHV</b>	Higher Heating Values

Abbreviation	Definition
<b>HIPPS</b>	High Integrity Pressure Protection System
<b>H<sub>2</sub>S</b>	Hydrogen Sulphide
<b>HC</b>	Hydrocarbon
<b>HPR</b>	Hydroacoustic Position Reference
<b>HR</b>	Human Resources
<b>HSE</b>	Health and Safety and Environment
<b>H&amp;S</b>	Health and Safety
<b>IAPCR</b>	Industrial Air Pollution Control Regulation
<b>IBA</b>	Important Bird Area
<b>IBC</b>	Intermediate Bulk Container
<b>IEA</b>	International Energy Agency
<b>IFC</b>	International Finance Corporation
<b>IFI</b>	International Financing Institutions
<b>IFRS</b>	International Financial Reporting Standards
<b>ICOMOS</b>	International Council on Monuments and Sites
<b>ILO</b>	International Labour Organisation
<b>IMO</b>	International Maritime Organisation
<b>IMS</b>	Integrated Management System
<b>INDC</b>	Intended Nationally Determined Contribution
<b>IPA</b>	Important Plant Area
<b>IPCC</b>	Intergovernmental Panel on Climate Change
<b>IPF</b>	Investment Project Financing
<b>IPIECA</b>	International Petroleum Industry Environmental Conservation Association
<b>ISO</b>	International Standards Organisation
<b>IUCN</b>	The International Union for Conservation of Nature
<b>KBA</b>	Key Biodiversity Area

Abbreviation	Definition
<b>Kg</b>	Kilogram
<b>kHz</b>	Kilohertz
<b>KII</b>	Key Informant Interview
<b>KM</b>	Kilometre
<b>Kolin</b>	Kolin Construction Tourism Industry and Trade Inc.
<b>KP</b>	Kilometer Point
<b>KPI</b>	Key Performance Indicator
<b>kt</b>	Kilo tonne
<b>ktCO<sub>2e</sub></b>	Kilo tonnes of carbon dioxide equivalent
<b>kV</b>	Kilovolt
<b>kW</b>	Kilowatt
<b>kW(e)</b>	Kilowatt electric
<b>KWh</b>	Kilowatt hour
<b>LC</b>	Least Concern
<b>LDAR</b>	Leak Detection and Repair
<b>L<sub>Aeq</sub></b>	A weighted equivalent sound pressure level.
<b>L<sub>Amax</sub></b>	The maximum A weighted sound pressure level detected in the measurement time domain
<b>L<sub>Ceq</sub></b>	C weighted equivalent sound pressure level.
<b>L<sub>day</sub></b>	Equivalent continuous sound pressure level for reference time interval day
<b>L<sub>den</sub></b>	Day, evening- night weighted sound pressure level. Day time defined in between 07:00-19:00, evening time between 19:00-23:00, night time between 23:00-07:00.
<b>L<sub>dn</sub></b>	Day-night-weighted sound pressure level. Day time defined in between 06:00-22:00, and night time defined as 22:00-06:00.
<b>L<sub>eq</sub></b>	Equivalent Sound Level
<b>L<sub>evening</sub></b>	Equivalent continuous sound pressure level for reference time interval evening

Abbreviation	Definition
<b>L<sub>night</sub></b>	Equivalent continuous sound pressure level for reference time interval night
<b>L<sub>p</sub></b>	Sound Pressure Level
<b>L<sub>w</sub></b>	Sound Power Level
<b>LPG</b>	Liquified Petroleum Gas
<b>LRP</b>	Livelihood Restoration Plan
<b>LULUCF</b>	Land Use, Land Use Change and Forestry
<b>M</b>	Meter
<b>m<sup>3</sup></b>	Cubic meter
<b>MAM</b>	Turkish Ministry of Environment and Urbanization and Marmara Research Center
<b>MEG</b>	Mono-Ethylene Glycol
<b>MMSm<sup>3</sup></b>	Million metric standard cubic meter
<b>mmBTU</b>	Million British Thermal Unit
<b>MmBTU/h</b>	Million British Thermal Unit per hour
<b>Mt CO<sub>2</sub>e</b>	megatonnes of carbon dioxide equivalent
<b>SCMD</b>	Standard cubic meter per day
<b>MoAF</b>	Ministry of Agriculture and Forestry
<b>MoC</b>	Management of Change
<b>MoEUCC</b>	Ministry of Environment, Urbanisation and Climate Change
<b>MoTI</b>	Republic of Turkey Ministry of Transportation and Infrastructure
<b>MT</b>	Metric Tonne
<b>MV</b>	Medium Voltage
<b>MWt</b>	Megawatt Thermal
<b>N<sub>2</sub>O</b>	Nitrous Oxide
<b>N/A</b>	Not Applicable
<b>N-CP</b>	Non-Compliance
<b>NE</b>	Northeasr



Abbreviation	Definition
<b>NGL</b>	Natural Gas Liquids
<b>NGO</b>	Non-governmental Organization
<b>NH<sub>4</sub></b>	Ammonium
<b>NIR</b>	National Inventory Report
<b>NO</b>	Nitrogen Oxide
<b>NO<sub>2</sub></b>	Nitrogen Dioxide
<b>NO<sub>x</sub></b>	Nitrogen Oxides
<b>NOAA</b>	National Oceanic and Atmospheric Administration
<b>NPS</b>	Non-party stakeholders
<b>NRU</b>	Nitrogen Removal Unit
<b>NT</b>	Near Threatened
<b>NW</b>	Northwest
<b>O<sub>3</sub></b>	Ozone
<b>OBS</b>	Observation
<b>ODS</b>	Ozone Depleting Substance
<b>OECD</b>	Organisation for Economic Co-operation and Development
<b>OHS</b>	Occupational Health and Safety
<b>OHSAS</b>	Occupational Health and Safety Assessment Series
<b>ONHO</b>	Turkish Naval Forces, Office of Navigation, Hydrography and Oceanography
<b>OPF</b>	Onshore Production Facility
<b>PA/CA</b>	Preventative Actions/Corrective Actions
<b>PAH</b>	Polycyclic Aromatic Hydrocarbon
<b>PAP</b>	Project Affected Person
<b>PCB</b>	Polychlorinated Biphenyls
<b>PETKİM</b>	Petkim Petrochemical Holding Corporation
<b>pH</b>	Potential of Hydrogen

Abbreviation	Definition
<b>PID</b>	Photoionization Detector
<b>PIF</b>	Project Information File
<b>PIG</b>	Pipeline Inspection Gauge
<b>PLET</b>	Pipeline End Termination
<b>PLR</b>	Pig Launcher Receiver
<b>PM</b>	Particulate Matter
<b>POM</b>	Princeton Ocean Model
<b>ppm</b>	Parts per million
<b>PS</b>	Performance Standard
<b>Pt-Co</b>	Platinum-Cobalt
<b>PWT</b>	Produced Water Treatment
<b>Q</b>	Flowrate
<b>R</b>	Rare
<b>RAEP</b>	Risk Assessment and Emergency Response Plan
<b>RAMEN</b>	Regulation on Assessment and Management of Environmental Noise
<b>RAP</b>	Resettlement Action Plan
<b>RCP</b>	Representative Concentration Pathway
<b>RIAPC</b>	Regulation on Industrial Air Pollution Control
<b>ROV</b>	Remotely Operated Vehicle
<b>RoW</b>	Rights of Way
<b>SEA</b>	Strategic Environmental Assessment
<b>SEP</b>	Stakeholder Engagement Plan
<b>SGFD</b>	Sakarya Gas Field Development (Unless otherwise stated, SGFD Project refers to the Phase 1 of the investment. SGFD Phase 1 is the topic of this ESIA)
<b>SIA</b>	Social Impact Assessment
<b>SO<sub>2</sub></b>	Sulphur Dioxide

Abbreviation	Definition
<b>SOP</b>	Standard Operating Procedure
<b>SPA</b>	Special Provincial Administration
<b>SPS</b>	Subsea Production System
<b>SRES</b>	Special Report on Emission Scenarios
<b>SSE</b>	South-Southeast
<b>SSW</b>	South-Soutwest
<b>SURF</b>	Subsea Umbilical, Risers and Flow Lines
<b>T</b>	Temperature
<b>t</b>	tonnes
<b>TANAP</b>	Trans-Anatolian Natural Gas Pipeline Project
<b>TBD</b>	To be Defined
<b>TCF</b>	Trillion cubic feet
<b>tCO<sub>2</sub>e/tLNG</b>	tonnes carbon dioxide equivalent per tonnes of liquefied natural gas
<b>TEDAŞ</b>	Turkey Electricity Distribution Inc.
<b>TEG</b>	Tri-ethylene Glycol
<b>TEİAŞ</b>	Turkish Electricity Transmission Company
<b>TEMA</b>	Turkish Foundation for Combating Erosion, Afforestation and Conservation of Natural Assets
<b>TCFD</b>	Task Force on Climate-related Financial Disclosures
<b>TJ</b>	Terajoule
<b>TL</b>	Turkish Liras
<b>TOC</b>	Total Organic Compound
<b>ToR</b>	Terms of Reference
<b>Tosyalı</b>	Tosyalı Holding
<b>TOX</b>	Total Organic Halides
<b>TPAO</b>	Turkish Petroleum Corporation
<b>TPH</b>	Total Petroleum Hydrocarbons

Abbreviation	Definition
<b>TP-OTC</b>	Turkish Petroleum Offshore Technology Center A.S.
<b>TR</b>	Turkish
<b>TS</b>	Turkish Standard
<b>TTK</b>	Turkish Hard Coal
<b>TURKSTAT</b>	Turkish Statistical Institute
<b>TÜBİTAK MAM</b>	Technological Research Council of Turkey
<b>TÜİK</b>	Turkish Statistical Institute
<b>TÜPRAŞ</b>	Turkish Petroleum Refineries Corporation
<b>UK</b>	United Kingdom
<b>UN</b>	United Nations
<b>UNFCCC</b>	United Nations Framework Convention on Climate Change
<b>UNEP</b>	United Nations Environment Programme
<b>UNESCO</b>	United Nations Educational, Scientific and Cultural Organization
<b>UV</b>	Ultraviolet
<b>UXO</b>	Unexploded Military Ordnance
<b>V</b>	Rapidly Becoming Extinct and at High Risk of Extinction
<b>VEC</b>	Valued Environmental Component
<b>VOC</b>	Volatile Organic Compound
<b>VU</b>	Vulnerable
<b>VPSHR</b>	Voluntary Principles on Security and Human Rights
<b>WHO</b>	World Health Organization
<b>WB</b>	World Bank
<b>WB ESF</b>	World Bank Environmental and Social Framework
<b>WD</b>	Water Depth
<b>WPCR</b>	Water Pollution Control Regulation
<b>WWTP</b>	Wastewater Treatment Plant
<b>XT</b>	Xmas Tree
<b>ZETES</b>	Zonguldak Eren Thermal Power Plant

Abbreviation	Definition
<b>ZONÇEB</b>	Zonguldak Special Administration And Municipalities Environment Infrastructure Services Union

## 1.0 INTRODUCTION

The Sakarya Gas Field Development Project (the Project) is planned by Turkish Petroleum Corporation (TPAO or Project Owner) to extract, transport to shore and process the natural gas discovered in the Sakarya Gas Field, in the exclusive economic zone of Turkey, off the Western Black Sea Region, and the natural gas reserves to be discovered through the ongoing exploration. Turkish Petroleum Offshore Technology Center (TP-OTC or Project Executor), 100% owned by TPAO will be conducting Project Management and Engineering, Procurement, Construction and Installation (EPCI) for the Project. Unless otherwise stated, SGFD Project refers to the Phase 1 of the investment. SGFD Phase 1 is the topic of this ESIA.

The Project consists of three main units, including the subsea production facility in Sakarya Gas Field, in the exclusive economic zone of Turkey, the onshore production facility (OPF) in Filyos Industrial Zone in the Çaycuma district of Zonguldak province, and two offshore pipelines for gas transportation from field to OPF and Mono-ethylene glycol (MEG) transportation from OPF to field, and an umbilical, all including shore crossings.

The investment will be realized in two phases, Phase 1 and Phase 2:

- Under **Phase 1**, natural gas to be produced with the subsea production system from 10 wells in Sakarya Gas Field will be transported onshore through a 16-inch (40.64 cm) diameter carbon steel pipeline, processed at the onshore production facility. In Phase 1, the daily production capacity will reach a maximum of 10 million standard m<sup>3</sup>.
- Under **Phase 2**, the natural gas whose production will continue in Sakarya Gas Field will be connected to the subsea production system with up to 30 additional wells reaching a total of up to 40 wells under Phase 2. A 24 inches pipeline (60.96 cm) or above will be needed to transport the additional gas produced in Phase 2.

Once processed at the onshore production facility, the gas produced by the Sakarya Gas Field will be measured at a Fiscal Metering Station (FMS) and offloaded to the national grid via a ~36 km onshore pipeline. Both the FMS and the pipeline will be designed, constructed, and operated by Petroleum Pipeline Corporation (“BOTAS”) and, in line with the OECD (Organisation for Economic Co-operation and Development) and IFC Performance Standards definition, will be considered as Associated facilities to the main Project.

The present document deals with the Phase 1 of the Project, whose description is included in Chapter 3.0 of the document. Because of the limited control by TP-OTC over the two BOTAS project’s components and considering that some construction works have already begun at the time of this document, it has been agreed among all parties involved to address the FMS and the onshore pipeline section in a High-level E&S Assessment Report included in Appendix A of this ESIA Report. Details of the approach undertaken are included in Chapter 3.1.1.2 Project Associated Facilities.

TP-OTC had a national Environmental Impact Assessment (EIA) prepared for the Phase 1 of the Project per the requirements of Turkish EIA Regulation. After the disclosure process, EIA Positive Decision was secured from the Ministry of Environment, Urbanization and Climate Change (MoEUCC) on Nov 26<sup>th</sup>, 2021. TP-OTC is considering receiving a loan from Export Credit Agencies (ECAs) or International Finance Institutions (IFIs) for purchase of Phase 1 Subsea Umbilical, Risers and Flow Lines (SURF).

A Gap Analysis Study, previously prepared by Golder Associates Turkey Ltd. (Golder) in December 2021, has identified gaps in the existing national EIA Report and included actions that need to be undertaken in order to close these gaps and reach a full Environmental and Social Impact Assessment (ESIA) compliant with the

Title:	<i>Chapter 1 - Introduction; Chapter 2 - Regulatory Framework; Chapter 3 - Project Description</i>	Classification:	Internal
DocID:	SC26-OTC-PRJ-EN-REP-000005	Page:	22 of 133
Rev. :	05		

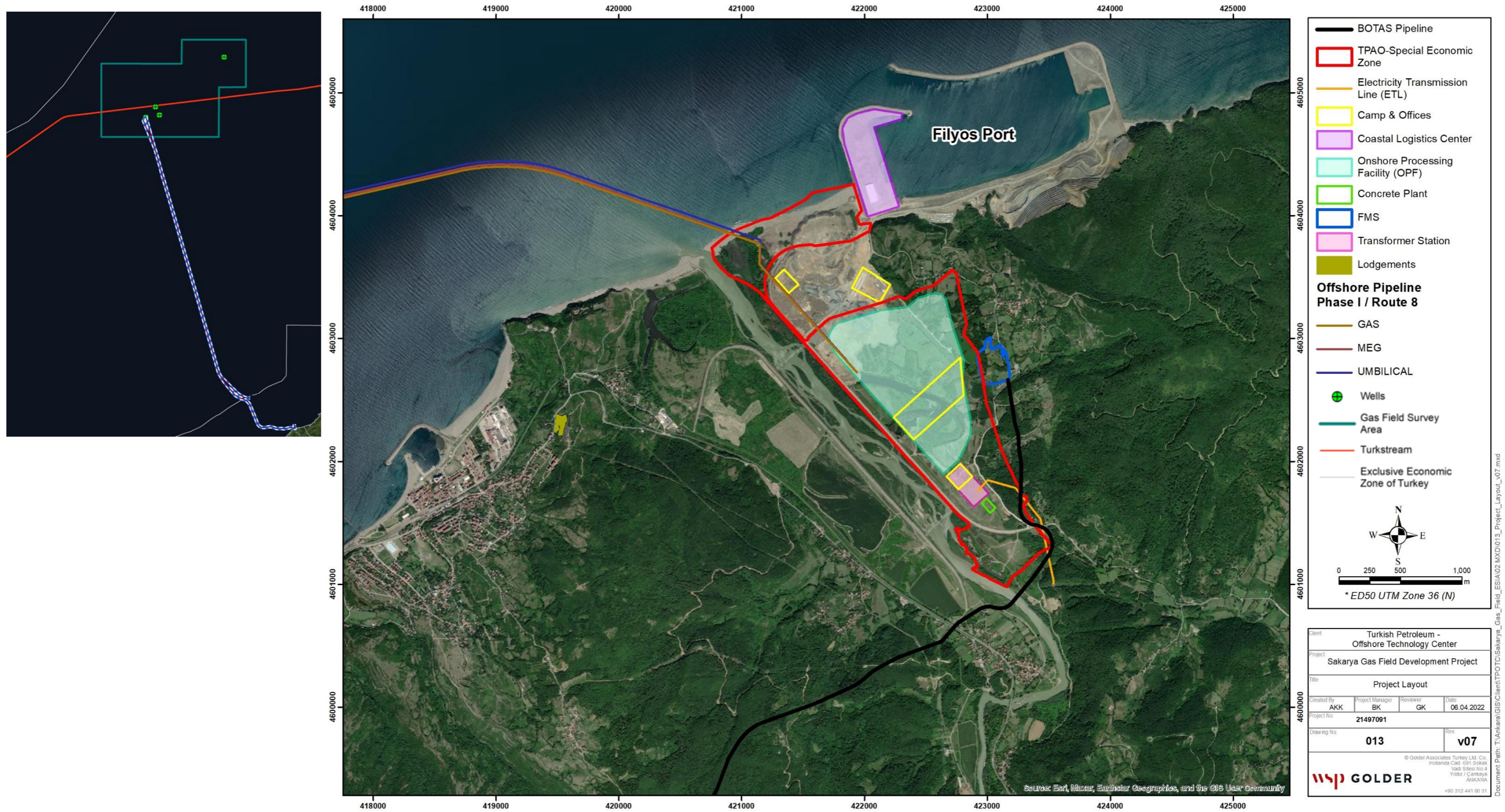
relevant International Standards (Equator Principles IV, World Bank Environmental and Social Framework and Environmental and Social Standards, IFC Performance Standards and Guidelines, and Good International Industrial Practice - GIIP).

Golder was retained by TP-OTC as a consultant to carry out an ESIA according to the findings of the Gap Analysis Study and further review of the Project design.

The potential lenders require the Project environmental and social information to be disclosed to stakeholders and this information is referred to as the disclosure package, which demonstrates Project's compliance with the lenders' requirements.

Layout showing Sakarya Gas Field Development Project and BOTAŞ FMS and Pipeline is presented below.

Title:	<i>Chapter 1 - Introduction; Chapter 2 - Regulatory Framework; Chapter 3 - Project Description</i>	Classification:	Internal
DocID:	SC26-OTC-PRJ-EN-REP-000005	Page:	23 of 133
Rev. :	05		



**Figure 1-1: Sakarya Gas Field Development Project, BOTAS FMS and Pipeline Layout**



## 1.1 Background on the Gas Field

Sakarya Gas Field is located within the Sakarya Gas Field Block C26 in the western Black Sea, approximately 165 km offshore Filyos, located in Zonguldak, Turkey. The Sakarya Gas Field is the first deepwater gas field discovery and the biggest natural gas reserve in the country. It is anticipated that 30% of the domestic natural gas demand will be met by the SGFD Project with the first production from the field planned in the first quarter of 2023.

Sakarya Gas Field discovery was initiated with the Tuna-1 deepwater exploration well, set at a depth of 2,115 m to reach a depth of 4,525 m, using its sixth generation deepwater drillship Fatih, in August 2020. The well intercepted more than 100 m of the natural gas-bearing reservoir in the Pliocene and Miocene sandstone formations. The initial natural gas reserve estimation was 320 billion cubic meters (bcm)/11 trillion cubic feet (tcf) of lean gas, which is considered the largest gas reserve discovered both in the Turkish Exclusive Economic Zone and in the Black Sea.

In the deeper sections of Tuna-1, a second discovery was made in October 2020, increasing the potential reserve estimate to 405bcm (14.3tcf) of lean gas. The discovery was made at a depth of 4,775 m in 2,117 m of water, where an additional 30 m of gas play was encountered in the reservoir in sandstones of the early-Pliocene to late-Miocene era.

In June 2021, further 135bcm gas was discovered through the drilling of the Amasra-1 exploration well by the Fatih drill ship, where the natural gas was intercepted at three levels between 3,000 m and 4,000 m.

## 1.2 Background on the Applicant, TPAO/TP-OTC

TPAO has been established in order to perform hydrocarbon exploration, drilling, production, refinery and marketing activities on behalf of the Turkish Republic with the Law no 6327, in 1954.

TPAO continued exploration, production, refining, marketing and transportation activities until 1983 as an integrated oil company. TPAO has been acting as a state-owned exploration and production oil company since the legal regulations made in 1983 and some other more recent changes.

TPAO brought 17 big oil and gas, petrochemicals companies such as PETKİM, TÜPRAŞ and PETROL OFİSİ to Turkey's economy for the first time in a period of more than half a century.<sup>1</sup>

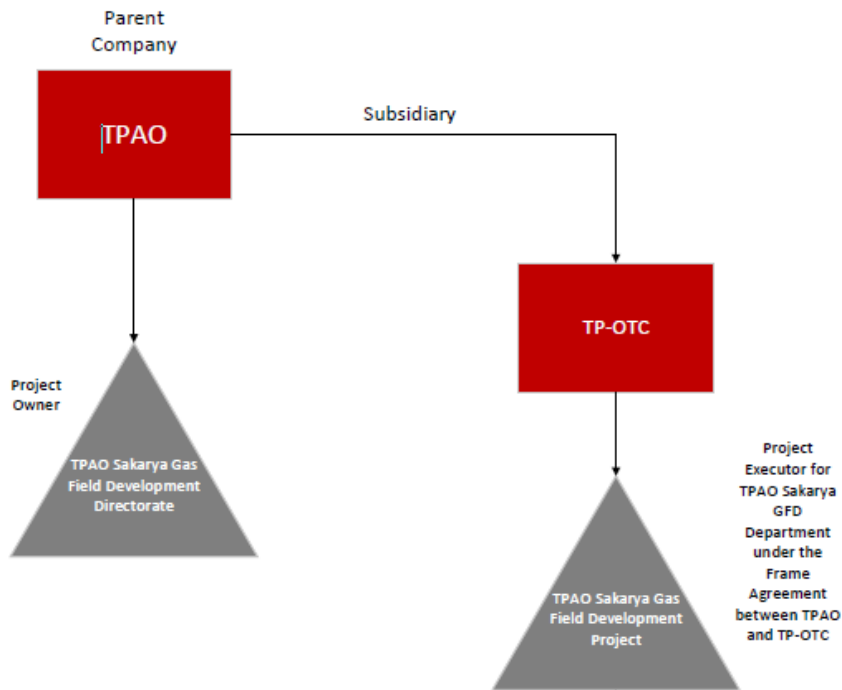
TP-OTC was founded on 12 March 2019 upon a Resolution of the Board of Directors of the main company TPAO, which conducts and supports petroleum and natural gas exploration and production activities at the seas of Turkey. The name TP-OTC was registered on 2 April 2019 following this resolution, and the company was structured specifically for the conducting of maritime operations.<sup>2</sup>

TP-OTC, 100% owned by TPAO will be conducting Project Management and EPCI for the Project.

<sup>1</sup> <https://www.tpao.gov.tr/en/about-tpao>

<sup>2</sup> <https://tp-otc.com/en/about-us/>

Title:	<i>Chapter 1 - Introduction; Chapter 2 - Regulatory Framework; Chapter 3 - Project Description</i>	Classification:	Internal
DocID:	SC26-OTC-PRJ-EN-REP-000005	Page:	25 of 133
Rev. :	05		



**Figure 1-2: Relation of TPAO and TP-OTC with the Project**

### 1.3 Purpose of the ESIA Report

#### 1.3.1 Objectives

A bankable ESIA needs to comply with both the national legislation and international standards. IFC Performance Standard 1 (IFC, 2012) lists the overall objectives for an ESIA, including:

- to identify and assess social and environmental impacts, both adverse and beneficial, in the project’s area of influence;
- to follow the mitigation hierarchy of avoidance, minimization and mitigation of impacts and if needed compensation, with respect to adverse impacts to workers, other affected people, and the environment;
- to conduct meaningful consultation; and
- to promote improved social and environmental performance of companies through the effective use of management systems.

As described in IFC Performance Standard 1, the main components of the assessment will include:

- the potential environmental and social impacts of the Project throughout the full development cycle – preconstruction, construction, operation, decommissioning;
- a public consultation and disclosure plan to ensure that local communities and other key stakeholders are informed of the Project and have an opportunity to express their opinions concerning the Project;
- proposed mitigation activities to minimize adverse environmental impacts;

Title:	Chapter 1 - Introduction; Chapter 2 - Regulatory Framework; Chapter 3 - Project Description	Classification:	Internal
DocID:	SC26-OTC-PRJ-EN-REP-000005	Page:	26 of 133
Rev. :	05		

- the nature and significance of residual impacts (those adverse impacts that occur after mitigation has been applied) and ongoing monitoring and management plans to address them;
- the nature and significance of cumulative impacts;
- a social management plan to maximize benefits to the local community and promote a sustainable economy.

The ESIA package consists of the following components:

- ESIA Report;
- Non-Technical Summary (NTS);
- Biodiversity Action Plan and Biodiversity Management Plan for the Onshore Dune Area Construction Phase;
- Stakeholder Engagement Plan (SEP);
- Livelihood Restoration Plan.

### 1.3.2 Categorization of the Project

According to the IFC’s Policy on E&S Sustainability (January 2012), as part of the review of environmental and social risks and impacts of a proposed investment, IFC uses a process of environmental and social categorization to reflect the magnitude of risks and impacts. The resulting category also specifies IFC’s institutional requirements for disclosure in accordance with the IFC’s Access to Information Policy. Accordingly, all projects are divided in four categories:

- Category A: business activities with potential significant adverse ES risks and/or impacts that are diverse, irreversible, or unprecedented;
- Category B: business activities with potential limited adverse ES risks and/or impacts that are few in number, generally site-specific, largely reversible, and readily addressed through mitigation measures;
- Category C: business activities with minimal or no adverse ES risks and/or impacts; and
- Category FI: business activities involving investments in financial intermediaries or through delivery mechanisms involving financial intermediation. This category is further divided into three risk categories (FI-1, FI-2, FI-3).

As per the E&S categorisation criteria of the applicable standards given below, the Project is categorised as “Category A.”

**Table 1-1: Project Categorisation According to Applicable Standards**

Applicable Standard	Category Explanation
IFC PSs (2012)	Category A: Business activities with potential significant adverse environmental or social risks and/or impacts that are diverse, irreversible, or unprecedented.
EPIV (2020)	Category A: Projects with potential significant adverse environmental and social risks and/or impacts that are diverse, irreversible or unprecedented.

Title:	<i>Chapter 1 - Introduction; Chapter 2 - Regulatory Framework; Chapter 3 - Project Description</i>	
DocID:	SC26-OTC-PRJ-EN-REP-000005	Classification: Internal
Rev. :	05	Page: 27 of 133

### **1.3.3 Steps of the ESIA**

#### **1.3.3.1 Gap Analysis**

Several documents have been prepared to support the National EIA approval and the international ESIA process. The first stage of the ESIA process has been preparing the gap analysis to identify deficiencies of the national EIA Report in relation to the relevant international standards, and to suggest actions to close these gaps. The overall role of the study was to review, existing technical documents, reports, studies to evaluate the possibility of using the data already available in the preparation of the international ESIA.

#### **1.3.3.2 Review of Additional Documentation**

An additional step of the ESIA preparation has been the review of supplementary documentation that has become available with the progress of the Project design. The review of the documentation has allowed the ESIA team to complete the gap analysis of the existing data and information as well as defining the methodology and structure of the ESIA and associated documents.

#### **1.3.3.3 Baseline Data Collection**

Baseline information for the ESIA is obtained from the Project specific social and environmental baseline studies that have been initiated during Gap Analysis process and carried out as part of this ESIA, utilising both desktop study and field-based approaches.

These studies have been compiled through specifically surveys and collated from a range of sources including publicly available information and through consultation with stakeholders. Relevant information used to support the assessment process is referenced in the relevant chapters and sections of this report.

#### **1.3.3.4 Stakeholder Engagement**

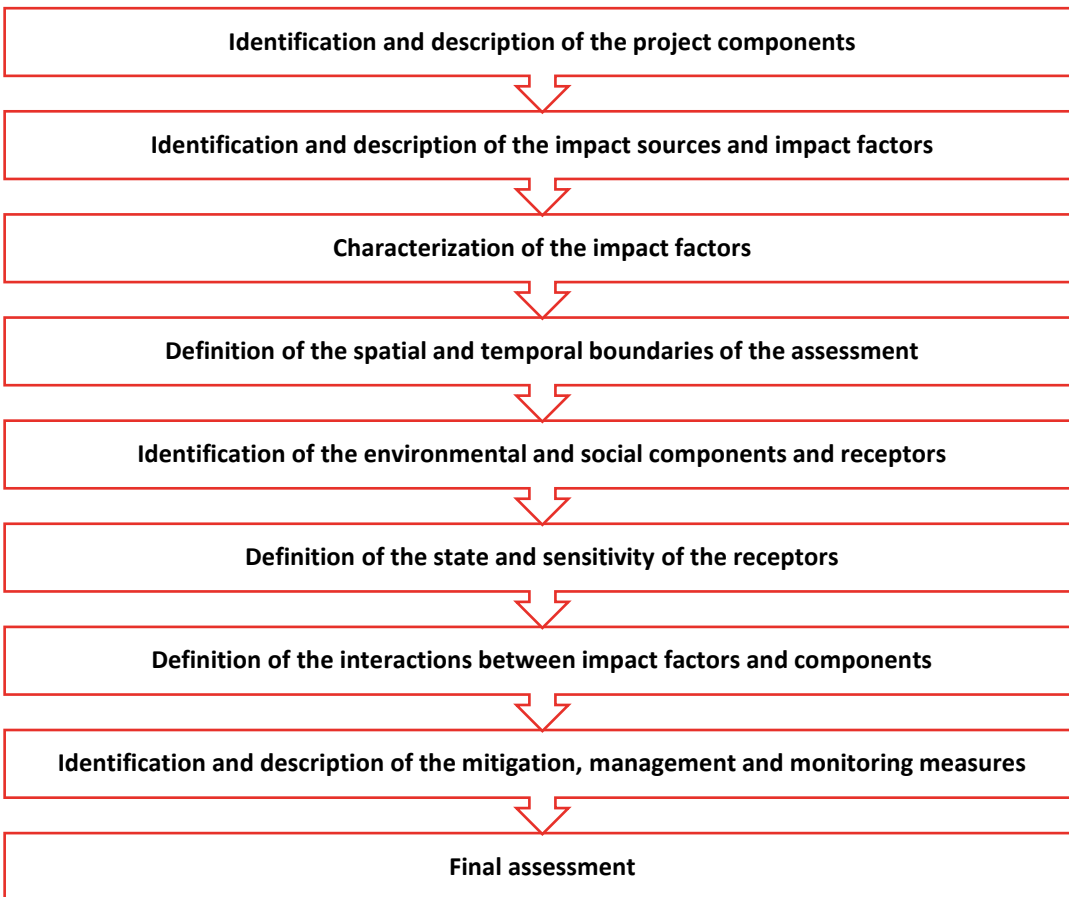
Stakeholder engagement is considered as an essential step for a successful management of the Project's environmental and social impacts (IFC PS1). Therefore, the most recent principles, regulations, and international standards and definitions were utilised to identify, approach and engage with all relevant stakeholders through a specifically developed stakeholder engagement program.

Stakeholder mapping and consultation activities have been initiated during Gap Analysis process and carried out as part of this ESIA resulting in a Stakeholder Engagement Plan (SEP) and grievance mechanisms that are presented in the chapters and sections of this report.

Title:	<i>Chapter 1 - Introduction; Chapter 2 - Regulatory Framework; Chapter 3 - Project Description</i>	Classification:	Internal
DocID:	SC26-OTC-PRJ-EN-REP-000005	Page:	28 of 133
Rev. :	05		

**1.3.3.5 Impact Assessment and Mitigation Measures**

The general methodology adopted by Golder for the ESIA has been designed to be highly transparent and to allow an analysis of the impacts on the various environmental and social components. The steps in Golder’s Impact Assessment methodology are the following:



**Figure 1-3: Steps of Golder's Impact Assessment methodology**

Golder's impact assessment methodology is described in detail in Chapter 5 of this report.

**1.4 Uncertainties**

This ESIA is prepared based on the Project information provided by the TP-OTC and the information collected during the site visits. Like most ESIA's, the current ESIA has faced a number of challenges in terms of retrieving baseline information, ongoing design changes until design is finalized, the level of accuracy of predicting impacts, and developing appropriate mitigations. Furthermore, even with a firm Project design and an unchanging environment, predictions are by definition, uncertain.

Areas of uncertainty, known or future likely data gaps and deficiencies are highlighted within the ESIA report. In order to address the uncertainties, monitoring will be undertaken by the TP-OTC to understand whether the identified mitigation measures are sufficient or there is a need for any refinements.

Title:	<i>Chapter 1 - Introduction; Chapter 2 - Regulatory Framework; Chapter 3 - Project Description</i>	Classification:	Internal
DocID:	SC26-OTC-PRJ-EN-REP-000005	Page:	29 of 133
Rev. :	05		

## 1.5 Environmental and Social Management and Monitoring

The applicable lenders standards require that an Environmental and Social Management System (ESMS) for the Project is prepared and implemented through the Project lifecycle. The general framework of the Project ESMS is described in Chapter 12 of this report.

## 1.6 Outline of the ESIA Report

This ESIA Report includes the following chapters:

- Introduction (Chapter 1);
- Regulatory and Policy Framework (Chapter 2);
- Project Description (Chapter 3);
- Alternatives Analysis (Chapter 4);
- ESIA Methodology (Chapter 5);
- Environmental and Social Baseline (Chapter 6);
- Impact Assessment and Mitigation (Chapter 7);
- Offshore Risk of Accidental Releases (Chapter 8);
- Climate Change Risk Assessment (Chapter 9);
- Cumulative Impact Assessment (Chapter 10);
- Residual Impacts and Conclusions (Chapter 11);
- Environmental and Social Management Framework (Chapter 12);
- References;
- Appendices.

Title:	<i>Chapter 1 - Introduction; Chapter 2 - Regulatory Framework; Chapter 3 - Project Description</i>	Classification:	Internal
DocID:	SC26-OTC-PRJ-EN-REP-000005	Page:	30 of 133
Rev. :	05		

## **2.0 REGULATORY AND POLICY FRAMEWORK**

This chapter provides an overview of the national and international regulatory framework, including policies, legislation, requirements, guidelines and standards applicable to the Project. In the presence of multiple standards coming from different regulatory sources, the Project will apply the most stringent standards in order to protect the environment and the communities potentially affected by the project.

Applicable Environmental and Social Requirements of the Project are defined based on the IFC Performance Standards (PS), Guidance Documents, World Bank Sectoral and General EHS Guidelines, Equator Principles (EP), World Bank Environmental and Social Framework (WB ESF) and World Bank Environmental and Social Standards (WB ESS) and the National Turkish legislation.

### **2.1 Applicable Turkish Legislation**

The Turkish legal framework for environmental protection was developed in line with national and international initiatives and standards, and some of them have been revised recently to be harmonized with the EU Directives in the scope of pre-accession efforts of Turkey to the EU. In the following sections, related institutions, legislation, processes, and procedures that are related to the environmental and social aspects of the proposed project are described.

The Ministry of Environment, Urbanization and Climate Change (MoEUCC) is the responsible organization for the issuing and implementation of policies and legislation adopted for protection and conservation of the environment and for sustainable development and management of natural resources.

The Ministry of Agriculture and Forestry (MoAF) is the responsible organization for the issuing and implementation of policies and legislation adopted for the protected areas.

The Turkish Environment Law No. 2872, which came into force in 1983, deals with environmental issues on a very broad scope. According to the basic principles that govern the application of the Environment Law, and as stated in the Constitution, citizens as well as the state bear responsibility for the protection of environment. Complementary to the Environment Law and its regulations, other laws also govern the protection and conservation of the environment, the prevention and control of pollution, and the implementation of measures for the prevention of pollution.

The Environment Law of 1983 has a comprehensive structure that has a holistic and integrated vision for the environment. “Polluter pays” and “user pays” principles and carrying capacity concepts form the basis of regulatory tools in the Environmental Law. The Law is supported by numerous regulations and decrees prepared or updated in the process of alignment with EU legislation, thus contributing significantly to compensating the gaps within the former legislative system of Turkey.

A list of regulations currently in force and applicable to the context of the Project are outlined in Appendix B.

#### **2.1.1 Labour and H&S Regulations**

Labour and occupational health & safety issues in Turkey are regulated by the Ministry of Labour and Social Security. Turkish law and the major regulations relevant to labour and working conditions are given in Appendix B.

Title:	<i>Chapter 1 - Introduction; Chapter 2 - Regulatory Framework; Chapter 3 - Project Description</i>	Classification:	Internal
DocID:	SC26-OTC-PRJ-EN-REP-000005	Page:	31 of 133
Rev. :	05		

## 2.1.2 Permitting Framework

The main permits and approvals applicable to the scope of works are given below (Table 2-1).

**Table 2-1: The Main Permits and Approvals Required**

Subject	Permit / Approval	Relevant Regulatory Framework
Land Use	Land use agreements for state owned lands <ul style="list-style-type: none"> <li>- Easement</li> <li>- Pre-Allocation of Space for the Onshore Production Facility</li> <li>- Preliminary Permit for Marine Spaces (Territorial Waters)</li> <li>- Approval Process for the Zoning Plans of the Sea Section</li> <li>- Approval Process for the Zoning Plans of the Onshore Section</li> <li>- Marine areas pre-usage permit</li> <li>- Approval of the Onshore Geological-Geotechnical Survey Report</li> <li>- Approval of the Offshore Geological-Geotechnical Survey Report</li> <li>- Zoning plans with a 1/5,000 and 1/1,000 scales for the Onshore Section</li> <li>- Zoning plans with a 1/5,000 and 1/1,000 scales for the SURF (for the portion from the coastal line of the SUEF up to the Turkish territorial waters)</li> </ul>	Relevant laws and regulations specific to the land use type <ul style="list-style-type: none"> <li>- Industrial Zones Law (No: 4737, 2002)</li> <li>- Regulation on the Management of Treasury Properties</li> <li>- Coastal Law No. 3621 and its sub-legislation</li> </ul>
	Permit for the use of agricultural lands for non-agricultural purposes (if required)	Law on Soil Protection and Land Use (No: 5403, 2005)
	Approval of expropriation plans (if required)	Expropriation Law (No: 2942, 1983)
	Permit for the use of forest lands (if required)	Forestry Law (No. 6831,1956) Implementation Regulation of 16th Article of the Forestry Law Implementation Regulation of 17/3rd and 18th Articles of the Forestry Law
	Permit for the use of pasture lands (change of the purpose of allocation) (if required)	Pasture Law (No: 4342, 1998)
	Establishing a transit agreement with the cable owners in the event a cable transit is encountered	-
	Confirmation from the Turkish Navy whether there is an existing unexploded military ordnance (UXO) on the pipeline route.	-
	Bathymetric and oceanographic report approval	Regulation on Navigation, Hydrography and Oceanography Services



Subject	Permit / Approval	Relevant Regulatory Framework
Construction	EIA Approval	Regulation on Environmental Impact Assessment
	Dredging conformity certificate Dredging permit	Regulation on Environmental management of Dredging Material Regulation on Sea and Inland water Drilling Regulation on Sea and Inland Water Drilling
	Waste transportation and acceptance certificate (excavation)	Regulation on the Control of Excavation Soil, Construction and Demolition Waste
	Permits and approvals for roads, water bodies, canals, energy supply lines, pipelines, utilization of municipal infrastructure etc.	Protocols/approvals/official letters of related state authorities
	Workplace notification for construction camp sites Site permits and subscriptions	Regulation on Starting Up and Operating a Workplace
	Construction permit	Industrial Zones Law (No: 4737, 2002)
	Permit for on-site fuel storage	Regulation on Environmental Permits and Licenses
	Approval of wastewater treatment plant application project	Wastewater Treatment/Deep Sea Discharge Facility Project Approval Circular No. 2018/14
	Temporary operating certificate/environmental permit (discharge, emission, etc.) for camp site wastewater discharge, emission due to heating, generator usage, concrete batching plant operation	Regulation on Environmental Permits and Licenses Regulation on Water Pollution Control
	EIA Decision for the concrete batching plant	Regulation on Environmental Impact Assessment
	Water use agreement with Filyos and Saltukova Municipalities	-
	Wastewater acceptance letter from the Çaycuma Municipality confirming that Municipality WWTP is capable of handling the load	-
	Waste management plan approval, Temporary storage permit (If a thousand kilograms or more of hazardous waste will be produced per month) Agreements made with licensed waste management and disposal companies	Waste Management Regulation
	Night work permit (if required)	Regulation on Assessment and Management of Environmental Noise

Title: *Chapter 1 - Introduction; Chapter 2 - Regulatory Framework; Chapter 3 - Project Description*

DocID: SC26-OTC-PRJ-EN-REP-000005

Rev. : 05

Classification: Internal

Page: 33 of 133

Subject	Permit / Approval	Relevant Regulatory Framework
	Private security permit	Regulation on the Implementation of the Law Concerning Private Security Services
Operation	Building permits, Occupancy permits	Zoning Law No. 3194 and its sub-legislation
	Energy identity certificate (for buildings)	Regulation on Energy Performance in Buildings
	Confirmation that the seabed umbilical and pipelines have been built in accordance with the project	Presidential Decree No. 1 on the Presidency Organization
	Fire report approval	Regulation on Fire Protection of Buildings
	Offshore facility emergency response plan approval	Law No. 5312 on the Principles of Emergency Response and Compensation for Damages in Pollution of the Marine Environment with Petroleum and Other Harmful Substances and its related regulations
	Approval of wastewater treatment plant application projects	Wastewater Treatment/Deep Sea Discharge Facility Project Approval Circular No. 2018/14
	Temporary operating certificate/environmental permit for wastewater discharge, emissions and noise (if required)	Regulation on Environmental Permits and Licenses
	Greenhouse gas emission monitoring report approval	Regulation on the Monitoring of Greenhouse Gas Emissions
	Groundwater use permit	Law on Groundwater Resources (No. 167, 1960)
	Waste management plan approval, Temporary Storage Permit (If a thousand kilograms or more of hazardous waste will be produced per month) Agreements made with licensed waste management and disposal companies	Waste Management Regulation
	Permit for on-site fuel storage	Regulation on Environmental Permits and Licenses
	Seveso declaration	Regulation on Prevention and Mitigation of Major Industrial Accidents
	Hazardous substance activity certificate	Directive on the Procedures and Principles Regarding Issuing Hazardous Substances Activity Document

Title: *Chapter 1 - Introduction; Chapter 2 - Regulatory Framework; Chapter 3 - Project Description*

DocID: SC26-OTC-PRJ-EN-REP-000005

Rev. : 05

Classification: Internal

Page: 34 of 133

Subject	Permit / Approval	Relevant Regulatory Framework
	Trial permit /Business licence	Regulation on Business License
	Business license for subsea production system	The Turkish Petroleum Law No. 6491
	Private security permit	Regulation on the Implementation of the Law Concerning Private Security Services

## 2.2 Applicable International Legislation

Turkey is a party to many international agreements regarding multiple social and environmental subjects. These are listed in in Appendix B and their applicability will be further discussed in the relevant chapters of this ESIA.

Turkey has also ratified the following international conventions and agreements related to human rights that apply may apply to this Project.

### Council of Europe Documents

- European Convention for the Protection of Human Rights and Fundamental Freedoms (As Amended by Protocol No. 11)
- Council of Europe Convention on the Prevention of Terrorism
- European Convention on the Exercise of Children's Rights
- Protocol No. 4 to the Convention for The Protection of Human Rights and Fundamental Freedoms Securing Certain Rights and Freedoms Other Than Those Already Included in the Convention and in the First Protocol Thereto
- Protocol to the Convention for the Protection of Human Rights and Fundamental Freedoms
- European Social Charter

### United Nations Documents

- The Statute of The Council of Europe
- Report of The Office of The United Nations High Commissioner for Human Rights on the International Workshop on Enhancing Cooperation Between International and Regional Mechanisms for The Promotion and Protection of Human Rights
- The Role of The Ombudsman, Mediator and Other National Human Rights Institutions in the Promotion and Protection of Human Rights
- International Covenant on Civil and Political Rights
- The Universal Declaration of Human Rights

### The ILO Conventions Ratified by Turkey

- C 2 Unemployment Convention, 1919

Title:	<i>Chapter 1 - Introduction; Chapter 2 - Regulatory Framework; Chapter 3 - Project Description</i>	Classification:	Internal
DocID:	SC26-OTC-PRJ-EN-REP-000005	Page:	35 of 133
Rev. :	05		

- C 11 Right of Association (Agriculture) Convention, 1921
- C 14 Weekly Rest (Industry) Convention, 1921
- C 15 Minimum Age (Trimmers and Stokers) Convention, 1921
- C 26 Minimum Wage-Fixing Machinery Convention, 1928
- C 29 Forced Labour Convention, 1930
- C 34 Fee-Charging Employment Agencies Convention, 1933
- C 42 Workmen's Compensation (Occupational Diseases) Convention (Revised), 1934
- C 45 Underground Work (Women) Convention, 1935
- C 53 Officers' Competency Certificates Convention, 1936
- C 55 Shipowners' Liability (Sick and Injured Seamen) Convention, 1936
- C 58 Minimum Age (Sea) Convention (Revised), 1936
- C 59 Minimum Age (Industry) Convention (Revised), 1937
- C 68 Food and Catering (Ships' Crews) Convention, 1946
- C 69 Certification of Ships' Cooks Convention, 1946
- C 73 Medical Examination (Seafarers Convention, 1946
- C 77 Medical Examination of Young Persons (Industry) Convention, 1946
- C 80 Final Articles Revision Convention, 1946
- C 81 Labour Inspection Convention, 1947
- C 87 Freedom of Association and Protection of the Right to Organise Convention, 1948
- C 88 Employment Service Convention, 1948
- C 92 Accommodation of Crews Convention (Revised), 1949
- C 94 Labour Clauses (Public Contracts) Convention, 1949
- C 95 Protection of Wages Convention, 1949
- C 96 Fee-Charging Employment Agencies Convention (Revised), 1949
- C 98 Right to Organise and Collective Bargaining Convention, 1949
- C 99 Minimum Wage Fixing Machinery (Agriculture) Convention, 1951
- C100 Equal Remuneration Convention, 1951
- C102 Social Security (Minimum Standards) Convention, 1952

Title:	<i>Chapter 1 - Introduction; Chapter 2 - Regulatory Framework; Chapter 3 - Project Description</i>	Classification:	Internal
DocID:	SC26-OTC-PRJ-EN-REP-000005	Page:	36 of 133
Rev. :	05		

- C105 Abolition of Forced Labour Convention, 1957
- C108 Seafarers' Identity Documents Convention, 1958
- C111 Discrimination (Employment and Occupation) Convention, 1958
- C115 Radiation Protection Convention, 1960
- C116 Final Articles Revision Convention, 1961
- C118 Equality of Treatment (Social Security Convention, 1962
- C119 Guarding of Machinery Convention, 1963
- C122 Employment Policy Convention, 1964
- C123 Minimum Age (Underground Work) Convention, 1965
- C127 Maximum Weight Convention, 1967
- C133 Accommodation of Crews (Supplementary Provisions) Convention, 1970
- C134 Prevention of Accidents (Seafarers) Convention, 1970
- C135 Workers' Representatives Convention, 1971
- C138 Minimum Age Convention, 1973
- C142 Human Resources Development Convention, 1975
- C144 Tripartite Consultation (International Labour Standards) Convention, 1976
- C146 Seafarers' Annual Leave with Pay Convention, 1976
- C151 Labour Relations (Public Service) Convention, 1978
- C152 Occupational Safety and Health (Dock Work) Convention, 1979
- C153 Hours of Work and Rest Periods (Road Transport) Convention, 1979
- C155 Occupational Safety and Health Convention, 1981
- C158 Termination of Employment Convention, 1982
- C159 Vocational Rehabilitation and Employment (Disabled Persons) Convention, 1983
- C161 Occupational Health Services Convention, 1985
- C164 Health Protection and Medical Care (Seafarers) Convention, 1987
- C166 Repatriation of Seafarers Convention (Revised), 1987
- C167 Safety and Health in Construction Convention, 1988
- C176 Safety and Health in Mines Convention, 1995

Title:	<i>Chapter 1 - Introduction; Chapter 2 - Regulatory Framework; Chapter 3 - Project Description</i>	Classification:	Internal
DocID:	SC26-OTC-PRJ-EN-REP-000005	Page:	37 of 133
Rev. :	05		

- C182 Worst Forms of Child Labour Convention, 1999
- C187 Promotional Framework for Occupational Safety and Health Convention, 2006.

**Other International Standards**

The following standards are referred to within the IFC Guidelines:

- WHO Ambient Air Quality Standards, and
- WHO Drinking Water Standards.

In addition, the following guidelines and standards may be utilized:

- Dutch Intervention Values for Soil Quality, as/if needed, and
- IUCN Red Data Book for protected species (fauna and flora).
- Guidance on Heritage Impact Assessments for Cultural World Heritage Properties, ICOMOS 2011

**2.3 Equator Principles, IFC Performance Standards, and WBG EHS Guidelines**

For the preparation of the present document, international conventions and agreements, ESIA International Standards (i.e., Equator Principles, and IFC Performance Standards and guidelines) have been analysed and considered together with national standards.

The Equator Principles Financial Institutions (EPFIs) emphasize that they will not provide loans to projects where the borrower will not or is unable to comply with the EPFIs social and environmental policies and procedures that implement the Equator Principles.

In addition, the Equator Principles endorse the applicable IFC Performance Standards, IFC General EHS Guidelines and IFC Industry Specific EHS Guidelines. The Performance Standards establish the standards that the project is to meet throughout the life of an investment by the IFC or other relevant financial institutions. General and Industry Specific EHS Guidelines provide implementation guidelines and environmental quality limits that projects should comply with.

The Equator Principles, the IFC Performance Standards and Other Guidelines are listed below.

**2.3.1 Equator Principles IV (2020)**

The Equator Principles Financing Institutions (EPFIs) have ten principles which are given below:

- Principle 1: Review and Categorization
- Principle 2: Environmental and Social Assessment
- Principle 3: Applicable Environmental and Social Standards
- Principle 4: Environmental and Social Management System and Equator Principles Action Plan
- Principle 5: Stakeholder Engagement

Title:	<i>Chapter 1 - Introduction; Chapter 2 - Regulatory Framework; Chapter 3 - Project Description</i>	Classification:	Internal
DocID:	SC26-OTC-PRJ-EN-REP-000005	Page:	38 of 133
Rev. :	05		

- Principle 6: Grievance Mechanism
- Principle 7: Independent Review
- Principle 8: Covenants
- Principle 9: Independent Monitoring and Reporting
- Principle 10: Reporting and Transparency

### **2.3.2 IFC Performance Standards (2012)**

The eight Performance Standards (PSs) establish the standards that a project is to meet throughout the life of an investment by the IFC or any other relevant financial institution. These are the following:

- Performance Standard 1: Assessment and Management of Environmental and Social Risks and Impacts
- Performance Standard 2: Labour and Working Conditions
- Performance Standard 3: Resource Efficiency and Pollution Prevention
- Performance Standard 4: Community Health, Safety, and Security
- Performance Standard 5: Land Acquisition and Involuntary Resettlement
- Performance Standard 6: Biodiversity Conservation and Sustainable Management of Living Natural Resources
- Performance Standard 7: Indigenous Peoples (not applicable to the Project)
- Performance Standard 8: Cultural Heritage

#### **2.3.2.1 IFC General EHS Guidelines**

The General EHS Guidelines (dated April 30<sup>th</sup>, 2007) provide guidance to users on common EHS issues potentially applicable to all industry sectors. During the design, construction, operation and decommissioning of a project (the project lifecycle) the project owner will consider ambient conditions and apply pollution prevention and control technologies and practices (techniques) that are best suited to avoid or, where avoidance is not feasible, minimize or reduce adverse impacts on human health and the environment while remaining technically and financially feasible and cost-effective. The project-specific pollution prevention and control techniques included in General EHS Guidelines involve the subjects listed below:

- Air emissions and ambient air quality,
- Energy conservation,
- Wastewater and ambient water quality,
- Water conservation,
- Hazardous materials management,
- Waste management,

Title:	<i>Chapter 1 - Introduction; Chapter 2 - Regulatory Framework; Chapter 3 - Project Description</i>	Classification:	Internal
DocID:	SC26-OTC-PRJ-EN-REP-000005	Page:	39 of 133
Rev. :	05		

- Noise,
- Contaminated land,
- Occupational Health & Safety,
- Community Health & Safety, and
- Construction and Decommissioning.

**2.3.2.2 IFC EHS Guidelines for Onshore Oil and Gas Development**

Published on May 31<sup>st</sup>, 2017 the EHS Guidelines for Onshore Oil and Gas Development include information relevant to seismic exploration; exploration and production drilling; development and production activities; transportation activities including pipelines; other facilities including pump stations, metering stations, pigging stations, compressor stations and storage facilities; ancillary and support operations; and decommissioning. The document addresses the following issues:

- Air Emissions,
- Wastewaters,
- Waste Management,
- Hazardous Material Management,
- Noise
- Terrestrial Impacts and Project Footprint
- Spills,
- Occupational Health & Safety,
- Community Health & Safety,
- Performance Indicators and Monitoring,
- Emissions, Effluent and Waste Levels,
- Occupational Health and Safety Monitoring,
- Occupational Health & Safety Guidelines,
- Accident and Fatality Rates.

**2.3.2.3 IFC EHS Guidelines for Offshore Oil and Gas Development**

Published on June 5<sup>th</sup>, 2015 the EHS Guidelines for Offshore Oil and Gas Development include information relevant to seismic exploration, exploratory and production drilling, development and production activities, offshore pipeline operations, offshore transportation, tanker loading and unloading, ancillary and support operations, and decommissioning. They also address potential onshore impacts that may result from offshore oil and gas activities. The document addresses the following issues:

Title:	<i>Chapter 1 - Introduction; Chapter 2 - Regulatory Framework; Chapter 3 - Project Description</i>	Classification:	Internal
DocID:	SC26-OTC-PRJ-EN-REP-000005	Page:	40 of 133
Rev. :	05		



- Air Emissions,
- Wastewaters,
- Waste Management,
- Hazardous Material Management,
- Noise
- Spills,
- Loading, Storage, Processing, and Offloading Operations,
- Occupational Health & Safety,
- Community Health & Safety,
- Emission and Effluent Guidelines,
- Environmental Monitoring,
- Occupational Health and Safety Monitoring,
- Occupational Health & Safety Guidelines,
- Accident and Fatality Rates.

**2.3.2.4 IFC EHS Guidelines for Electric Power Transmission and Distribution**

Published on April 30<sup>th</sup>, 2017, the EHS Guidelines for Electric Power Transmission and Distribution include information relevant to power transmission between a generation facility and a substation located within an electricity grid, in addition to power distribution from a substation to consumers located in residential, commercial, and industrial areas. The document addresses the following issues:

- Terrestrial habitat alteration
- Aquatic habitat alteration
- Electric and magnetic fields
- Hazardous materials
- Occupational Health and Safety
- Community Health and Safety

**2.3.2.5 IFC EHS Guidelines for Shipping**

Published on April 30<sup>th</sup>, 2017 the EHS Guidelines for Shipping include information relevant to the operation and maintenance of ships used for the transport of bulk cargo, and goods. The document addresses the following issues:

- Petroleum and Hazardous Materials Management,

Title:	<i>Chapter 1 - Introduction; Chapter 2 - Regulatory Framework; Chapter 3 - Project Description</i>	Classification:	Internal
DocID:	SC26-OTC-PRJ-EN-REP-000005	Page:	41 of 133
Rev. :	05		

- Wastewater and Other Effluents,
- Air Emissions,
- Waste,
- Noise
- Occupational Health & Safety,
- Community Health & Safety,

**2.3.2.6 Performance Indicators and Monitoring, Documents Pertaining to Human Rights**

The IFC’s Sustainability Framework – consisting of the Policy on Environmental and Social Sustainability, Performance Standards on Environmental and Social Sustainability, and Access to Information Policy – were released publicly on August 1<sup>st</sup>, 2011, with an effective date of January 1<sup>st</sup>, 2012.

The external context has evolved rapidly in certain thematic areas, including increased attention towards climate change, ecosystem services, financial intermediaries, and human rights. With regard to the latter, the consultation process confirmed that human rights are now a major sustainability issue for businesses and their stakeholders. The IFC’s commitment to respecting human rights in its business activities is captured in the Sustainability Policy, while IFC Owners’ responsibility to respect human rights is captured in Performance Standard 1. Other provisions in the Performance Standards also support various human rights relevant to business. In that context, many human rights risks for business can be effectively addressed through social and environmental considerations. Some major items in that respect will be under the categories of:

- Labour and Working Conditions;
- Community Health, Safety, and Security;
- Land Acquisition and Involuntary Resettlement;
- Indigenous Peoples (not applicable to the Project); and
- Cultural Heritage.

**2.3.2.7 Other IFC Guidelines**

IFC Guidelines that are applicable to the Project are provided as follows:

- IFC’s Good Practice Note on Addressing Grievances from Project-Affected Communities (2009)
- IFC’s Good Practice Note on Managing Contractors’ Environmental and Social Performance (2017)
- IFC’s Good Practice Handbook on Use of Security Forces: Assessing and Managing Risks and Impacts (2017)
- IFC’s Handbook for Addressing Project-Induced In-Migration (2009)
- IFC’s Introduction to Health Impact Assessment (2009)

Title:	<i>Chapter 1 - Introduction; Chapter 2 - Regulatory Framework; Chapter 3 - Project Description</i>	Classification:	Internal
DocID:	SC26-OTC-PRJ-EN-REP-000005	Page:	42 of 133
Rev. :	05		

- IFC and EBRD's Guidance Note on Workers' Accommodation: Processes and Standards (2009)
- IFC's Good Practice Handbook on Cumulative Impact Assessment and Management: Guidance for the Private Sector in Emerging Markets (2013)
- IFC's Environmental and Social Management System Implementation Handbook: Construction (2014)
- IFC's Environmental and Social Management System Implementation Handbook: General (2015)
- IFC's Stakeholder Engagement Handbook: A Good Practice Handbook for Companies Doing Business in Emerging Markets (2007)
- Interim Advice for IFC Clients on Supporting Workers in the Context of COVID-19

### **2.3.3 Environmental Limits**

A list of potentially applicable limits and criteria derived from the applicable requirements are presented in Appendix C for each environmental component. The strictest of limits are marked as Project Standards.

Title:	Chapter 1 - Introduction; Chapter 2 - Regulatory Framework; Chapter 3 - Project Description	Classification:	Internal
DocID:	SC26-OTC-PRJ-EN-REP-000005	Page:	43 of 133
Rev. :	05		

## 3.0 PROJECT DESCRIPTION

This chapter describes the design philosophy of the Project, the construction schedules and the characteristics of the Project stages (or Phases); Construction, Operation and Decommissioning. It also describes the principal materials, equipment infrastructure used for the construction, wastes and emissions associated with the Project, and labour requirements.

### 3.1 Project Overview and Schedule

#### 3.1.1 Project Description

Sakarya Gas Development Project aims to extract, transmit to the shore and process the natural gas, discovered in Sakarya Gas Field.

The Project investment will be realized in two phases, Phase 1 and Phase 2:

- Under **Phase 1**, natural gas to be produced with the Subsea Production System (SPS) from 10 wells in Sakarya Gas Field will be transported to the onshore through a 16-inch (40.64 cm) diameter carbon steel pipeline, processed at the Onshore Production Facility (OPF). In addition, 10.75-inch (27.3 cm) Monoethylene glycol (MEG) pipeline and an umbilical will be installed to operate the production system. In Phase 1, the daily production capacity will reach a maximum of 10 million standard m<sup>3</sup>.
- Under **Phase 2**, the natural gas whose production will continue in Sakarya Gas Field will be connected to the SPS with up to 30 additional wells, transported to onshore with pipelines and processed in the OPF. With Phase 2, production will be realized from a total of up to 40 wells. A pipeline with a diameter of 24 inches (60.96 cm) or above will be needed to transport the gas produced in Phase 2. It is expected that the MEG pipeline to be installed in Phase 1 will be sufficient for both phases.

In addition, a Fiscal Metering Station (FMS) and a 36 km natural gas pipeline will be designed, constructed, and operated by Petroleum Pipeline Corporation (“BOTAŞ”) to offload gas from the OPF to the national grid. These two facilities are not treated as part of the main Projects’ components as under the full control of BOTAŞ and considered Associated Facilities (see Appendix A for the specific standalone E&S Assessment carried out).

Production under the Project is planned to start within 2023. The realization and operation at full capacity of the project will produce 40 million standard m<sup>3</sup> of natural gas daily. This production will reach the ratio of meeting Turkey’s natural gas demands domestically up to 30%.

The present ESIA deals with the **Phase 1** of the Project since the details and schedule of the Phase 2 components have not been finalized yet.

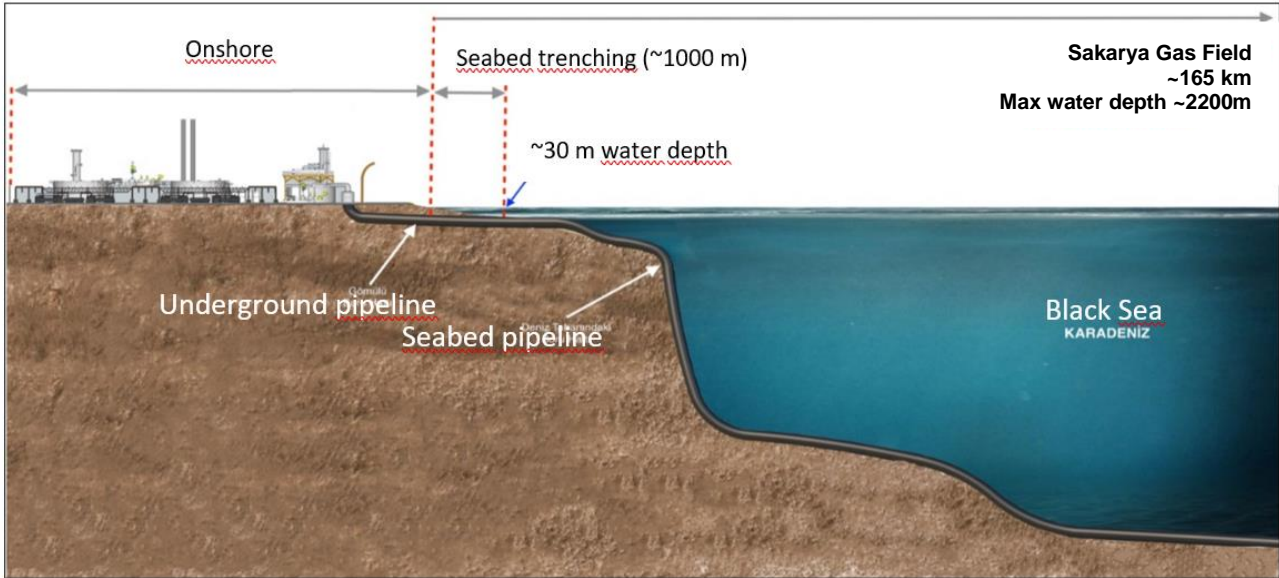
#### 3.1.1.1 Project Components

The Project (Phase 1) consists of three main units, including:

- Subsea Production System (SPS) in Sakarya Gas Field;
- Onshore Production Facility; and
- Two offshore pipelines for gas transportation from field to OPF and MEG transportation from OPF to field, and an umbilical, all including shore crossings (SURF).

Title:	Chapter 1 - Introduction; Chapter 2 - Regulatory Framework; Chapter 3 - Project Description	
DocID:	SC26-OTC-PRJ-EN-REP-000005	Classification: Internal
Rev. :	05	Page: 44 of 133

Geographically, these main units are located in the offshore section, the shore crossing section, and the onshore section.



**Figure 3-1: Illustration of Main Project Units**

All Project components/units are given in detail in:

- Chapter 3.2 Subsea Production System (SPS) (Unit);
- Chapter 3.3 SURF (Subsea Pipelines and Umbilical, including shore crossings) Unit;
- Chapter 3.4 Onshore Production Facility (OPF) (Unit);
- Chapter 3.5 Transformer Station and Energy Transmission Line (Project component of the OPF);
- Chapter 3.6 Construction Camp Sites & Permanent Lodgings (Project component dealing with all Units)

The Illustration of the Project will be as below when completed.

Title:	Chapter 1 - Introduction; Chapter 2 - Regulatory Framework; Chapter 3 - Project Description	Classification:	Internal
DocID:	SC26-OTC-PRJ-EN-REP-000005	Page:	45 of 133
Rev. :	05		



**Figure 3-2: Project Renders**

Title:	<i>Chapter 1 - Introduction; Chapter 2 - Regulatory Framework; Chapter 3 - Project Description</i>	Classification:	Internal
DocID:	SC26-OTC-PRJ-EN-REP-000005	Page:	46 of 133
Rev. :	05		

### 3.1.1.2 Project Associated Facilities

According to the OECD definition and IFC Performance Standards, Associated Facilities are defined as:

- OECD - “Associated facilities are those facilities that are not a component of the project but that would not be constructed or expanded if the project did not exist and on whose existence the viability of the project depends; such facilities may be funded, owned, managed, constructed and operated by the buyer and/or project sponsor or separately from the project.”
- IFC – PS1 par. 8 – “Associated facilities, which are facilities that are not funded as part of the project and that would not have been constructed or expanded if the project did not exist and without which the project would not be viable”

Under the understanding that the ~36 km pipeline will have the sole purpose to offload the gas from the TP-OTC processing facility to the national grid, both the BOTAS pipeline and FMS have been considered as associated facilities. However, the following objective limitations have been considered:

- TP-OTC and BOTAŞ operating under different management systems autonomously.
- Limited control by TP-OTC over BOTAŞ in terms of work schedule, availability of project details and the possibility of requesting the implementation of specific mitigation measures on E&S matters.
- Construction works of the two FMS and pipeline have already begun at the time of this document. As of April 2022, the following activities have been completed/ are ongoing:
  - route clearance for the first 10 km and at the FMS site location;
  - topsoil stripping (without proper topsoil conservation);
  - mobilization and stacking of pipes at three locations;
  - transport and storage of pipe string elements along the first 10 km of the pipeline route;
  - urgent expropriation decision undertaken;
  - set-up of the office site inside the FMS boundaries site close to Sazköy, and
  - set-up of the camp site close to Sazköy.

Accordingly, it was not feasible to apply in this ESIA the same approach used for the main Project components (e.g., SPS, SURF, OPF, etc.) for the FMS and pipeline due to lack of i) basic information to assess the impact of the components with the same level of detail as the Project components; ii) difficulty in obtaining baseline information related to the abovementioned actions already completed; and iii). temporal gap for applying mitigation measures on BOTAŞ project actions already implemented.

All these limitations are clearly addressed in the EBRD PRs and IFC PSs as follows:

- *EBRD PR1 – par. 9: “Where the client cannot control or influence these activities or facilities, the environmental and social assessment process should identify the corresponding risks they present to the project. Where potentially significant adverse environmental and/or social risks relating to third party*

Title:	Chapter 1 - Introduction; Chapter 2 - Regulatory Framework; Chapter 3 - Project Description	Classification:	Internal
DocID:	SC26-OTC-PRJ-EN-REP-000005	Page:	47 of 133
Rev. :	05		

*activities or facilities are identified, the client should collaborate with those relevant third parties to manage and mitigate these risks.”*

- *IFC GN1 – Par. 3 - “At times, the assessment and management of certain environmental and social risks and impacts may be the responsibility of the government or other third parties over which the client does not have control or influence. Examples of where this may happen include: (i) when early planning decisions are made by the government or third parties which affect the project site selection and/or design; and/or (ii) when specific actions directly related to the project are carried out by the government or third parties such as providing land for a Project which may have previously involved the resettlement of communities or individuals and/or leading to loss of biodiversity. While the client cannot control these government or third-party actions, an effective ESMS should identify the different entities involved and the roles they play, the corresponding risks they present to the client, and opportunities to collaborate with these third parties in order to help achieve environmental and social outcomes that are consistent with the Performance Standards. In addition, this Performance Standard supports the use of an effective grievance mechanism that can facilitate early indication of, and prompt remediation for those who believe that they have been harmed by a client’s actions.”*

Taking these aspects into consideration, it has been agreed among all parties involved in the SGFD Project to address the FMS and the onshore pipeline section through a high-level E&S Assessment Report to identify key environmental and social risks and a Management and Corrective Action Plan (this report) with a list of site-specific mitigations measures focused on the construction phase of both the pipeline and the FMS. The document addresses the gaps identified and/or indicates if additional specific actions/documents are needed to ensure alignment between the two projects’ components and the relevant Lenders’ standards. The E&S Assessment Report is included in Appendix A.

### **3.1.1.3 Other Facilities**

#### **Sakarya Gas Field – Block C 26**

Sakarya Gas Field is located in the exclusive economic zone of Turkey, off the Western Black Sea Region.

Block C 26 is located 165 km from the coast at a depth of about 2,200 m. Gas explorations and wells installation in this area have both been undergoing since October 2020 and are forecasted to continue well into 2023. The area is undergoing completion of Phase 1, with four of the ten wells already installed, while Phase 2 will possibly see an up to 30 additional wells installed starting from 2023. After completion of Phase 1, the Sakarya Gas Field is expected to reach a daily production capacity of 10 million standard m<sup>3</sup>. EIA Exemption letter was obtained from the MoEUCC regarding exploration activities.

In the scope of the Project, Sakarya Gas Field Block C 26 will be the production area of the gas to be transported to the onshore production facility.

According to IFC the Social and Environmental Impact Assessment process is a way to identify, predict and assess the type and scale of potential impacts, and opportunities to benefit conservation. Considering that the drilling of the Phase 1 wells was already about completed at the time of the start of this ESIA (December 2021), the inclusion of the Phase 1 wells in the ESIA would have been a useless exercise, of difficult feasibility and the mitigations identified (if any) could have not been properly implemented. Furthermore, the Phase 1 wells existed prior to the Phase 1 Project object of the present ESIA (including the SPS the Onshore Production Facility and

Title:	<i>Chapter 1 - Introduction; Chapter 2 - Regulatory Framework; Chapter 3 - Project Description</i>	
DocID:	SC26-OTC-PRJ-EN-REP-000005	Classification: Internal
Rev. :	05	Page: 48 of 133



the offshore pipelines) and were not financed by Lenders and still. For these reasons, the Phase 1 wells were considered as “other facilities” and were included in the ESIA at the cumulative impact level only.

**Coastal Logistics Centre (CLC)**

Ministry of Transport and Infrastructure allocated the CLC, which is located within the boundaries of the Port of Filyos, to TP-OTC to be used for the coordination of supply and logistics on sea drilling operations in the Black Sea Region, as well as the berthing of drilling support vessels and the loading of drilling equipment on these vessels. CLC operates for the storage of water-based and oil-based drilling chemicals, the supply and storage of the requirements for drilling operations and workers on board, as well as the separation of drilling fluid and sludge that is generated during the drilling activities undertaken by TPAO in Sakarya Natural Gas Basin of the Western Black Sea. The CLC has an area of approximately 24 hectares. Project Information File (PIF) has been prepared and “EIA Not Required” decision was obtained for the CLC on Jan 20<sup>th</sup>, 2021.

CLC is fenced and there is a controlled entry/exit gate. In the scope of the Project, a designated area inside the CLC will be used for the temporary storage of pipes and equipment and as a workshop/maintenance area during construction phase; Currently, a prefabricated building and office building is available at the designated area and additional offices are planned for the contractors. Water winning spread will be located at Filyos Port quayside for supply of filtered seawater during flooding, cleaning, gauging and hydrotest activities and also transfer of Lean MEG from Filyos Port to plant tanks for initial filling and for MEG system filling. Water winning spread will be located at southwest corner of Filyos Port on quay or at maximum distance of 35 m away from quay edge. Final location will be selected within this area. Hoses/pipeline will be placed inside existing culverts heading west across free corridor for transportation and finally reaching Terminal that will be established in the Block 1 zone of the OPF. Hose/pipeline will be suitable to transport seawater and Lean MEG. Hose/pipeline will be temporary and will be used during all Pre-commissioning/First fill phase. Provision of 2,000 m long hose/pipeline has been planned to take into account pressure drop and flow rate needed for all activities. Route is not clear at this stage. CLC will also be used for marine vessel berthing.

During operation, MEG will be received at CLC and transferred to OPF through tankers or an underground pipeline. The design is not clear at this stage.



**Figure 3-3: Aerial View of Water Winning Spread at CLC**

Title:	<i>Chapter 1 - Introduction; Chapter 2 - Regulatory Framework; Chapter 3 - Project Description</i>	Classification:	Internal
DocID:	SC26-OTC-PRJ-EN-REP-000005	Page:	49 of 133
Rev. :	05		

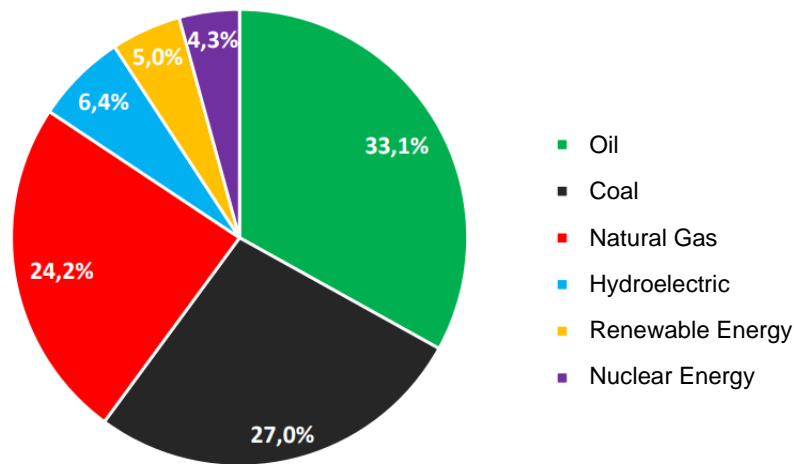
**Filyos Port**

Filyos Port, owned by Ministry of Transport and Infrastructure, is under construction. Filyos Port will primarily serve the Filyos Industrial Zone, which is planned to be established across the Filyos River. Filyos Port/Industrial Zone Connections Project (Project) is planned by the Ministry of Transport and Infrastructure, General Directorate of Infrastructure Investments, to carry out transportation and distribution of goods arriving at Filyos Port.

In the scope of the Project, Filyos Port will also be used for marine vessel berthing and SPS equipment maintenance, site receipt and pre-deployment tests before installation.

**3.1.2 Project Rationale**

Energy is one of the most basic and driving requirements of a country's economic and social development. In this respect, "Energy Security" is one of the vital elements of economic security and national security. Energy is an indispensable input for almost all processes necessary to sustain our social lives; It is used in industry, transportation, housing and commercial sub-sectors. While the energy consumed in the world today is obtained from many energy sources; Fossil resources such as oil, natural gas and coal constitute approximately 84% of these resources.<sup>3</sup>



**Figure 3-4: Global Primary Energy Consumption Rates in 2019<sup>4</sup>**

As a strategic primary energy source, natural gas, the use of which is spreading rapidly in the world and in Turkey, is rapidly taking the place of other fossil energy sources. Natural gas is an energy source that is more environmentally friendly than other fossil energy sources, pollutes the air less than other fossil fuels, and is less harmful to nature. Natural gas is preferred significantly due to its high calorific value and other qualities. It provides energy saving as it is more suitable for automatic control during combustion. Compared to many alternative fuels, its cheapness, ease of use, lack of stocking problems, etc. advantages have increased the demand for natural gas rapidly.

<sup>3</sup> TPAO, 2020 Oil and Natural Gas Sector Report, 2021

<sup>4</sup> BP Statistical Review of World Energy, 2020

Title:	<i>Chapter 1 - Introduction; Chapter 2 - Regulatory Framework; Chapter 3 - Project Description</i>	Classification:	Internal
DocID:	SC26-OTC-PRJ-EN-REP-000005	Page:	50 of 133
Rev. :	05		

When the energy consumption trends in Turkey according to their sources are examined, it is seen that the primary energy supply was mainly oil and coal before the 1980s. With the commissioning of natural gas in 1987, natural gas consumption has increased rapidly over the years. Given Turkey's natural gas consumption amounts in 2010-2020, it is seen that the consumption amount that was 37,411 standard million m<sup>3</sup> in 2010 increased to 48,261 standard million m<sup>3</sup> in 2020. Thus, the natural gas consumption increased by 29% in 2010-2020. National natural gas consumption amounts by years are given in Table 3-1.<sup>5</sup>

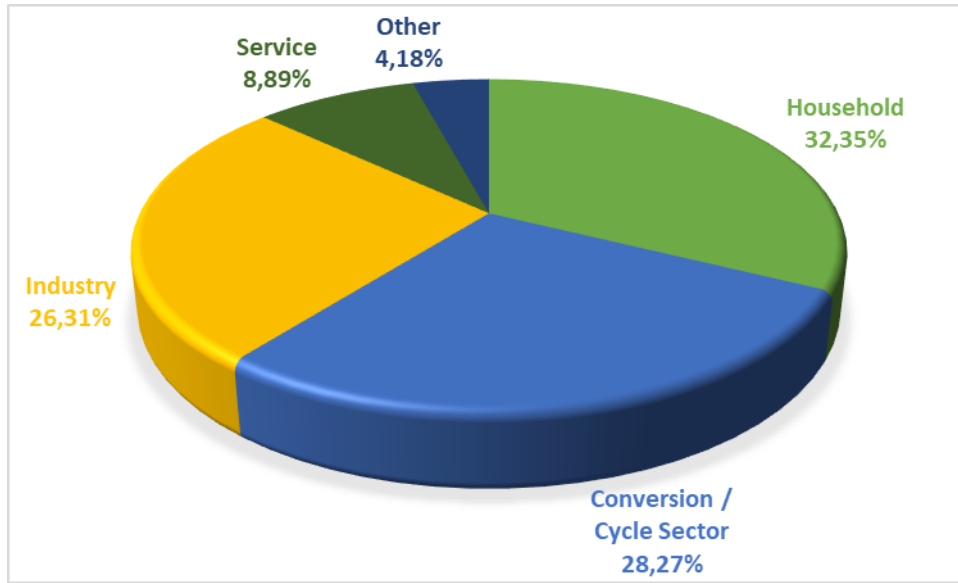
**Table 3-1: Total Natural Gas Consumption Amounts in Turkey by Years (Million Sm3)**

Year	Consumption (million Sm3)	Change from previous year (%)
2010	37,411	6.22
2011	43,697	16.8
2012	45,242	3.53
2013	45,918	1.5
2014	48,717	6.1
2015	47,999	-1.47
2016	46,480	-3.16
2017	53,857	15.87
2018	49,204	-8.64
2019	45,286	-7.96
2020	48,261	6.57

With its developing economy, Turkey is among the world's major energy consumers. When the sectoral distribution of 2020 is calculated as a percentage; residential consumption is 32.35%, consumption for electricity generation is 28.27%, and industrial consumption is 26.31%. This distribution, which also covers other basic sectors, can be seen in Figure 3-5.<sup>6</sup>

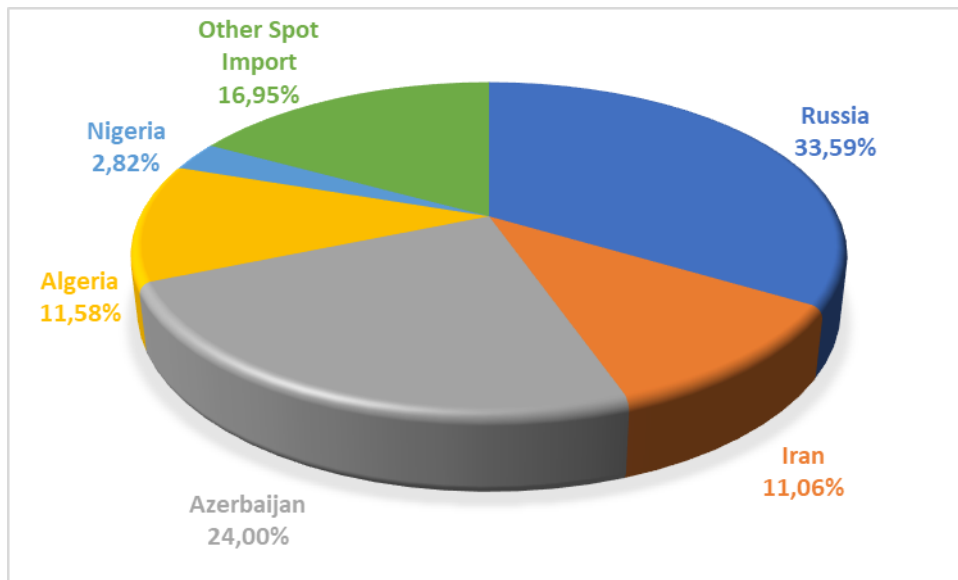
<sup>5</sup> TR. Energy Market Regulatory Authority (EPDK), Natural Gas Market 2020 Sector Report, 2021

<sup>6</sup> TR. Energy Market Regulatory Authority (EPDK), Natural Gas Market 2020 Sector Report, 2021



**Figure 3-5: 2020 Natural Gas Sectoral Consumption Distribution in Turkey (%)**

Turkey is a country that is heavily dependent on imports of natural gas. The rate of foreign dependency in natural gas consumption is higher than oil, and approximately 98.9% of Turkey's natural gas consumption is met by imports. While approximately 44.8 billion m<sup>3</sup> of natural gas was consumed in Turkey in 2020, only 1.1% of this amount (441 million m<sup>3</sup>) was met by domestic production. Most of the imports come from Russia. Distribution of natural gas imported by Turkey in 2020 by source countries is shown in the below figure.



**Figure 3-6: Share of Imported Natural Gas by Source Country in 2020**

The Blue Stream Natural Gas Pipeline and TurkStream Gas Pipeline between Russia and Turkey, the natural gas pipeline between Iran and Turkey, Trans-Anatolian Natural Gas Pipeline Project (TANAP) between

Azerbaijan and Turkey were built and put into operation for supply through pipeline. TANAP and TurkStream Gas Pipelines also reach Europe over Turkey and contribute to meet Europe’s natural gas demand.

Natural gas import has become mandatory for Turkey due to the fact that domestic reserves and production amounts remain at very limited levels in order to meet the current and potential use of natural gas, whose usage rate and areas are increasing due to the advantages it has in parallel with the increase in energy demand.

However, a shortage of supply is encountered frequently due to political issues or technical problems. Due to these reasons arising from suppliers and transit countries and technical reasons, Turkey has faced with situations where natural gas supply was realized below the daily gas contract values, especially in winter, and thus difficulties were experienced in maintaining the daily supply-demand balance.<sup>7</sup>

Offshore exploration activities, which were accelerated in order to increase the rate of meeting Turkey’s increasing oil and natural gas demand with domestic production, gave its first results with the natural gas reserve detected in the Sakarya Gas Field in 2020.

Within the scope of the project, an annual production of 3.5 billion m<sup>3</sup> will be achieved in Phase 1, followed by an annual production of 14 billion m<sup>3</sup> in Phase 2, and 30% of Turkey’s total consumption will be met. It is estimated that the project will start production in 2023 and the natural gas needs of approximately 2.5 million households will be met in Phase 1. With the realization of the Project, Turkey will be able to use its own resources in the near future, and thus, will decrease the share of energy in total importation significantly and make great contributions to the country’s economy.

### **3.1.3 Project Parties**

List of main Project parties:

- TPAO: Investor, responsible for exploration and drilling activities, operation processes will be taken over by TPAO;
- TP-OTC: Project owner, subsidiary of TPAO, responsible for conducting Project Management and EPCI for the Project, operator of subsea and onshore facilities;
- Sakarya Gas Field Development Directorate: Project executor under the Frame Agreement between TPAO and TP-OTC;
- BOTAŞ (Petroleum Pipeline Corporation): state-owned crude oil and natural gas pipelines and trading company in Turkey
- Schlumberger: OPF main contractor, responsible for commissioning, first 3-year operations and maintenance.
- Güngör Elektrik, Transformer Station and ETL contractor, responsible for commissioning, first 3- year operations and maintenance, if required.
- Other Contractors: parties and their scope are defined below.

Main contractors and their scope are listed in below.

<sup>7</sup> TR. Energy Market Regulatory Authority, 2021, Natural Gas Market 2020 Sector Report

Title:	<i>Chapter 1 - Introduction; Chapter 2 - Regulatory Framework; Chapter 3 - Project Description</i>	Classification:	Internal
DocID:	SC26-OTC-PRJ-EN-REP-000005	Page:	53 of 133
Rev. :	05		

**Table 3-2: Project Main Contractors and Scope of Works**

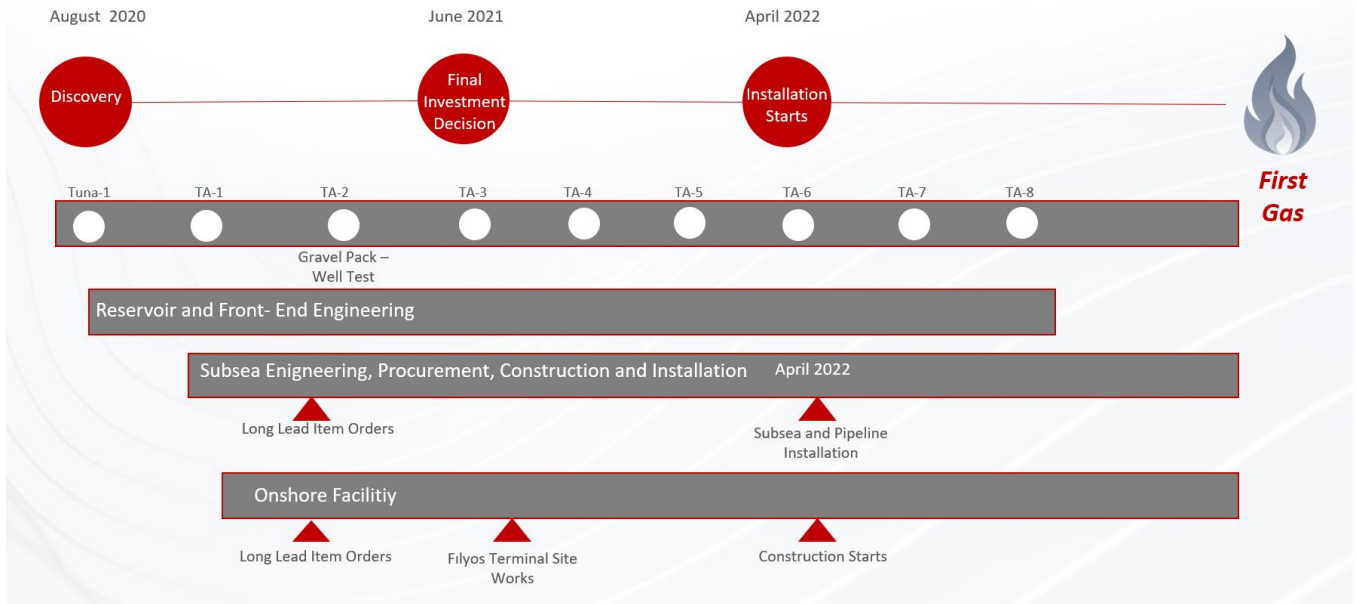
Project Component	Main Contractor	Scope of Work
SPS	OneSubsea (EPCI)	SPS Equipment and Tooling: project management, procurement, fabrication, logistics, delivery
	Schlumberger (EPCI)	Well Completion Equipment and Chemicals: project management, procurement, fabrication, logistics, delivery
SURF	Subsea7 (EPCI)	Pipelines and Umbilical: project management, procurement, fabrication, logistics, delivery, seabed interventions, installations (pipelines, umbilical and SPS system components), pre-commissioning and commissioning support
OPF	Schlumberger (EPCI)	OPF construction: project management, procurement, fabrication, logistics, delivery, construction, commissioning, 3-years operation and maintenance
	Kolin (EPCI)	Soil improvement works
Transformer Station and Energy Transmission Line	Güngör Elektrik (Direct Contractor)	Transformer station and energy transmission line construction: land acquisition of energy transmission line, commissioning, 3-years operation and maintenance of transformer station

### 3.1.4 Project Schedule

Project is handed over to TP-OTC once the wellheads are installed. First gas feed to network is planned in 2023. It is foreseen that the Project will remain in operation for 25-40 years. The operating period can extend following new explorations. The Project lifespan is depicted in the below figure. A detailed Project Schedule is presented in Appendix D.

Construction schedule of ETL is presented in Appendix D.

Construction of lodgings that will be used in the construction and subsequent phases of the Project is planned to start in July 2022 and completed in January 2024.



**Figure 3-7: Provisional Project Schedule \*TA: Türkali Well**

### 3.1.5 Project Location and Land Ownership

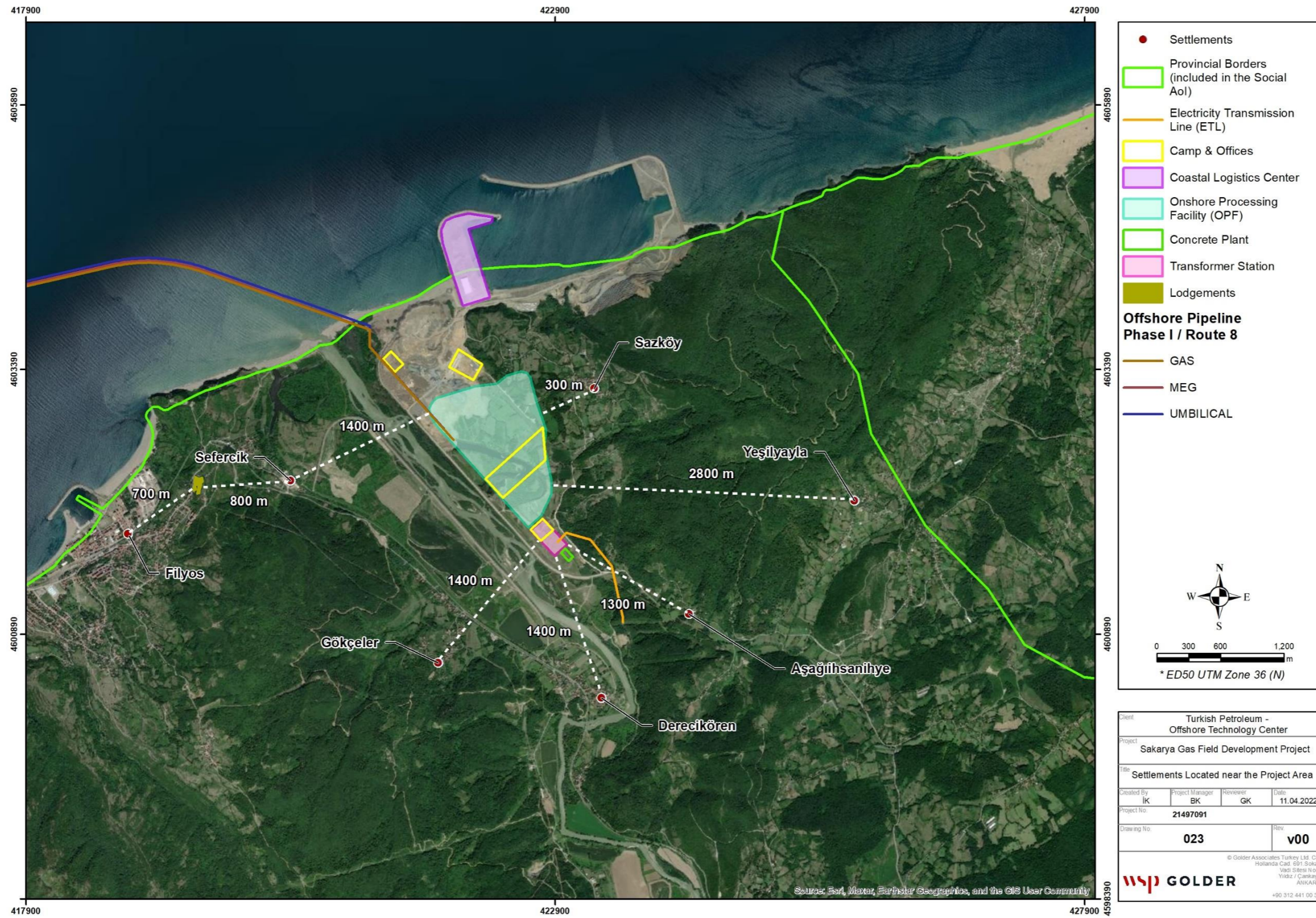
The onshore facilities of the Project will be located in Zonguldak City, Çaycuma District, 25 km from Zonguldak city centre and 15 km from Çaycuma district centre beeline. The nearest settlement to the OPF site is Sazköy Village, which is located at approximately 300 meters east.

OPF is bounded by:

- North: Black Sea
- Northeast: Coastal Logistics Centre
- East: Sözköy Village
- West: Filyos River and Filyos Industrial Zone (under construction)
- South: Derecikören Village
- Southeast: Aşağıhsaniye Village

Figure 3-8 provides the distance of the Project facilities from the closest settlements.

Title:	Chapter 1 - Introduction; Chapter 2 - Regulatory Framework; Chapter 3 - Project Description	Classification:	Internal
DocID:	SC26-OTC-PRJ-EN-REP-000005	Page:	55 of 133
Rev. :	05		



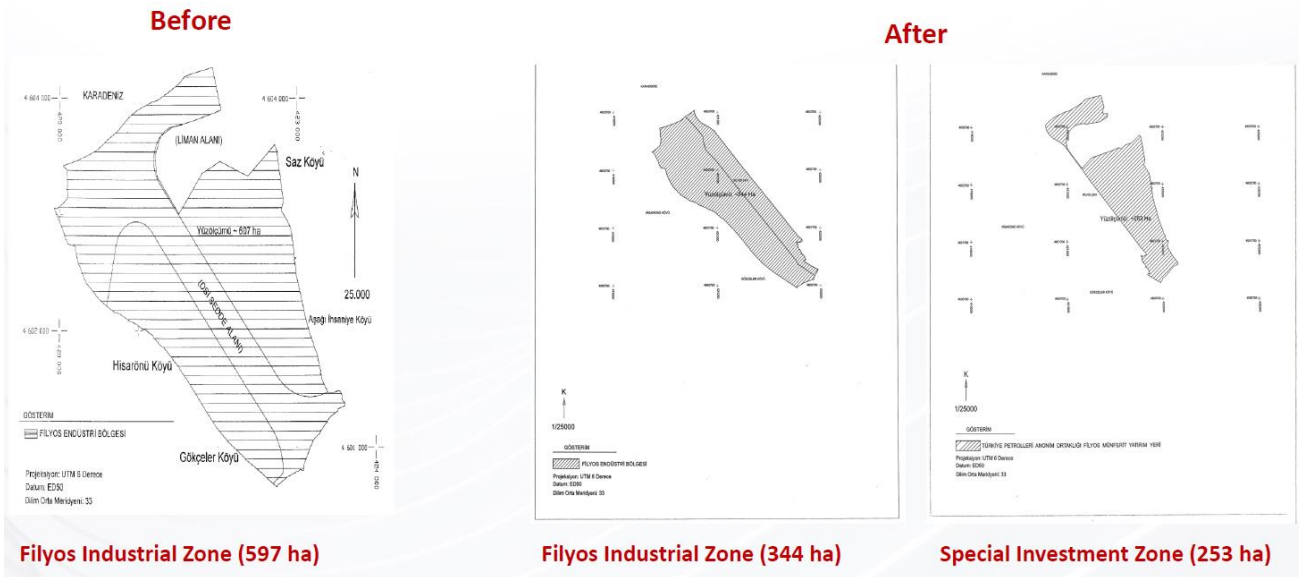
**Figure 3-8: Nearest Settlements Map**



The ownership status of the onshore areas of the Project is summarized below:

- The industrial zone area, where the OPF (including transformer station) will be constructed, is owned by the treasury and assigned to Turkish Ministry of Industry and Technology. Upon assent of Turkish Ministry of Industry and Technology, the pre-easement of this land was granted to TPAO. After EIA Positive Decision was obtained, right of easement was granted by General Directorate of National Real Estate to TPAO for 49 years for the Project, with the consent of Ministry of Industry and Technology. With the Presidential Decree No. 5071 published in the Official Gazette dated 6 January 2022, this area was removed from the Filyos Industrial Zone area and allocated to TPAO as a special economic zone. Previous and current status of the land is illustrated in Figure 3-9.
- The area between the shoreline and OPF, where the SURF passes through, is partly in the industrial zone and partly in the area where the right of easement was given in favour of the Ministry of Transport and Infrastructure and the use of land in the zoning plans was determined as a coastal logistics center. With the Presidential Decree No. 5071 published in the Official Gazette dated 6 January 2022, the part of the area (industrial zone) was allocated to TPAO as an individual investment site and consent/easement was made with the Ministry of Transport and Infrastructure for the other part.
- Energy transmission line passes through forest land which belongs to treasury except 1 private agricultural land. Agricultural land will be expropriated, and non-agricultural land use permit will be obtained from the Provincial Directorate of Agriculture and Forestry if required. Forest land will be allocated after the permission to be obtained from the Provincial Directorate of Agriculture and Forestry.
- Temporary camp site of Kolin is located in the land allocated to Ministry of Transport and Infrastructure for the Port construction and camp site of Subsea7 is located within the land of which preliminary consent/easement was made with the Ministry of Transport and Infrastructure while Schlumberger camp site is located inside OPF boundaries that is allocated to TPAO as a special economic zone.
- In addition, lodgings are planned on an area of 2 hectares, approximately 1.8 km west of the Project area, to be used in the construction and subsequent phases of the Project. TPAO purchased the title deed from the Ministry of National Defense.

Title:	<i>Chapter 1 - Introduction; Chapter 2 - Regulatory Framework; Chapter 3 - Project Description</i>	Classification:	Internal
DocID:	SC26-OTC-PRJ-EN-REP-000005	Page:	57 of 133
Rev. :	02		



**Figure 3-9: Previous and Current Land Status of the Filyos Industrial Zone and TPAO Special Investment Zone**

The part of the Project located on the seaside of shore edge line (onshore stretch of the Phase 1 SURF: MEG pipeline + gas pipeline) is situated within the state-owned lands, and the utilization permit for the area up to the boundary of territorial waters have been obtained from the Directorate General of National Property.

In the Project's offshore section, one part of the subsea umbilical and pipelines are located in Turkey's territorial waters with a width of 12 nautical miles, while the other part is located in Turkey's exclusive economic zone. The entire subsea production system is located over 165 km offshore, at a depth of approximately 2,200 m, within the Turkey exclusive economic zone. Turkey's right of usage for the territorial waters located on the seaside of the Project is set out in the Territorial Waters Law. TPAO is not required to acquire any lands in this area.

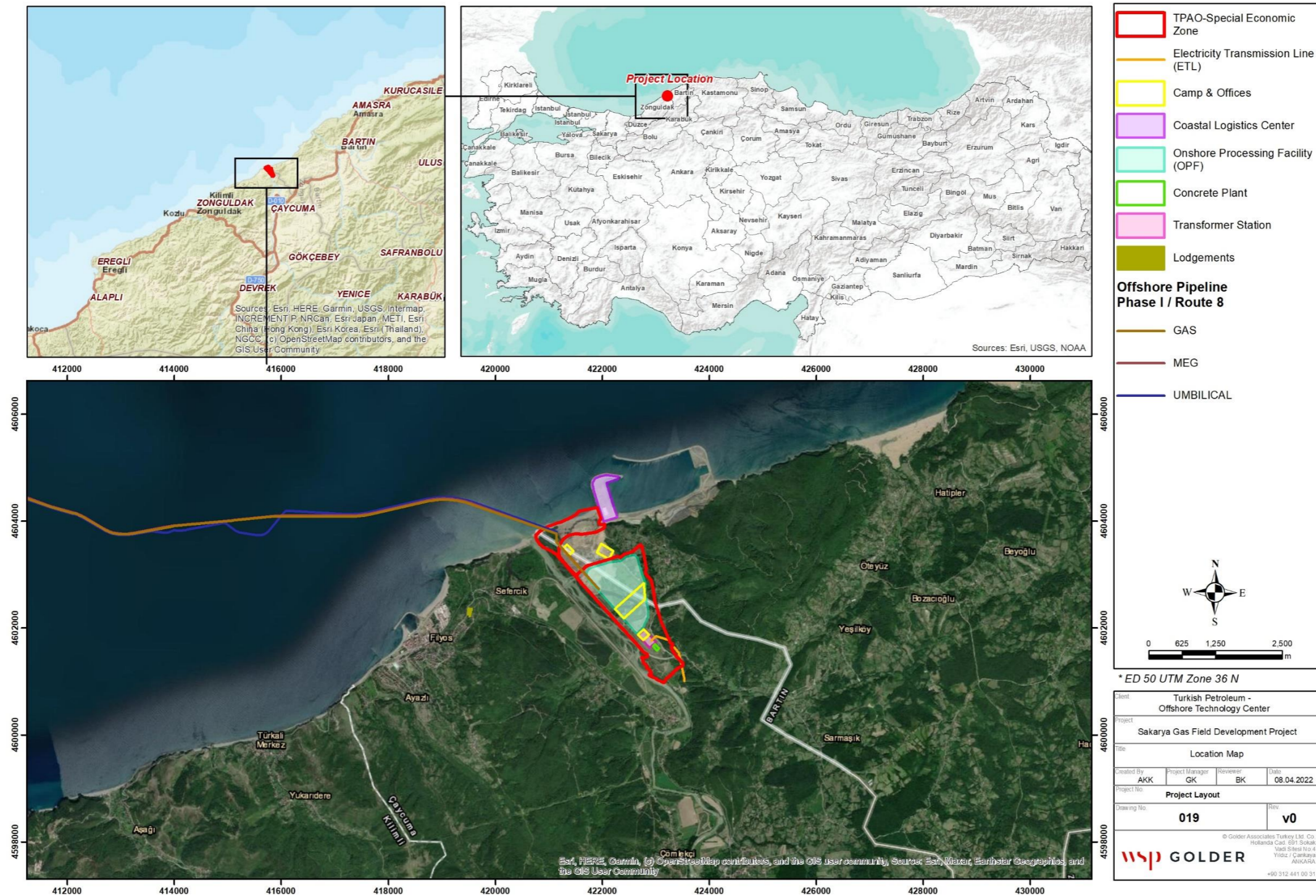
The onshore part of the Project site was used as a stockpile area during the construction of Filyos Port before it was declared an industrial zone. With the declaration of the site as an industrial zone, the Ministry of Industry and Trade gave the operator company (Tosyalı) "Preliminary Use Permit" and soil improvement works were started. After the area was declared as special investment zone and EIA Positive Decision was obtained, pre-emption of this land was granted to TPAO and soil improvement works were taken over.

Excess excavation material from the construction of Filyos Port and Industrial Zone is currently stored as stocks at the site. Some of this material is currently being transported to be used in the soil improvement works of the industrial zone located on the opposite side of Filyos River and in the ongoing construction works of Filyos Port. Some part of it will be used in the soil improvement works of the Project area.

The existing roads will be used in the Projects' construction phase and no link road is planned. For the construction of the ETL, existing forest roads will be used and no additional access road will be opened.

Project location map is given in Figure 3-10.

Title:	Chapter 1 - Introduction; Chapter 2 - Regulatory Framework; Chapter 3 - Project Description	Classification:	Internal
DocID:	SC26-OTC-PRJ-EN-REP-000005	Page:	58 of 133
Rev. :	02		



**Figure 3-10: Site Location Map**

### 3.1.6 Labor and Working Conditions

#### Workforce

It is planned to employ 1,900 people as a maximum for Phase 1 of the construction of the offshore section of the Project. A maximum of 6,500 people will work during the construction of the Project's onshore section (Phase 1).

It is planned to employ 120 people for Phase 1 operation and 270 people for Phase 2 operation. No personnel will work in the offshore section during the operation phase.

As of September 2022, 6,361 people are employed under TP-OTC, main contractors and sub-contractors within the scope of the Project. Distribution of workers according to their profession, company, locality and gender is presented below:

**Table 3-3: Employee Numbers as of September 2022**

Company	Skilled			UnSkilled			Total Number of Employees (employed as of Sep, 2022)	Total # of Locals	Total Number of Women Workers
	Total	#Locals*	%Locals*	Total	#Locals	%Locals*			
TP-OTC	339	158	47%	212	205	97%	551	363	66
Kolin	404	133	33%	148	95	64%	552	228	11
Güngör Elektrik	109	109	100%	18	18	100%	127	127	1
Schlumberger	4062	1035	25%	651	350	54%	4713	1385	208
Subsea 7	349	111	32%	69	40	58%	418	151	33
<b>TOTAL</b>	<b>5263</b>	<b>1546</b>		<b>1098</b>	<b>708</b>		<b>6361</b>	<b>2254</b>	<b>319</b>

\* Affected province-level (included Zonguldak and Bartın provinces)

Unskilled: No specific skill required to perform the job

Skilled: Possessing and/or demonstrating accomplishment, skill or specialised training

#### Temporary Worker Accommodation and Permanent Lodgings

A large proportion of the workforce will be accommodated in the construction camps that will be established in autonomy by the contractors. There will be contractor camp sites of Subsea 7, Güngör Elektrik, Schlumberger and their subcontractors, TP-OTC and other authority contractor camp site (existing Kolin camp site). The rest will be accommodated in rental houses and hotels in the vicinity of the Project area.

In addition, lodgings are planned on an area of 2 hectares, approximately 1.8 km west of the OPF, to be used in the construction and subsequent phases of the Project.

Details about the camps and permanent lodgings are given in Chapter 3.6.

Title:	Chapter 1 - Introduction; Chapter 2 - Regulatory Framework; Chapter 3 - Project Description	Classification:	Internal
DocID:	SC26-OTC-PRJ-EN-REP-000005	Page:	60 of 133
Rev. :	05		

**Working Hours**

Construction working hours are planned to be 08:30 to 17:30 Monday to Friday and 08:30 to 14:00 on Saturdays. Night working is implemented depending on the progress of the works within the legal limits. As of April 2022, construction works continue in 3 shifts of 8 hours each. During working during the hours of darkness, temporary lighting is applied. Lighting strategy is being arranged to minimise light pollution and glare to the community, road users and the shoreline while not comprising safety.

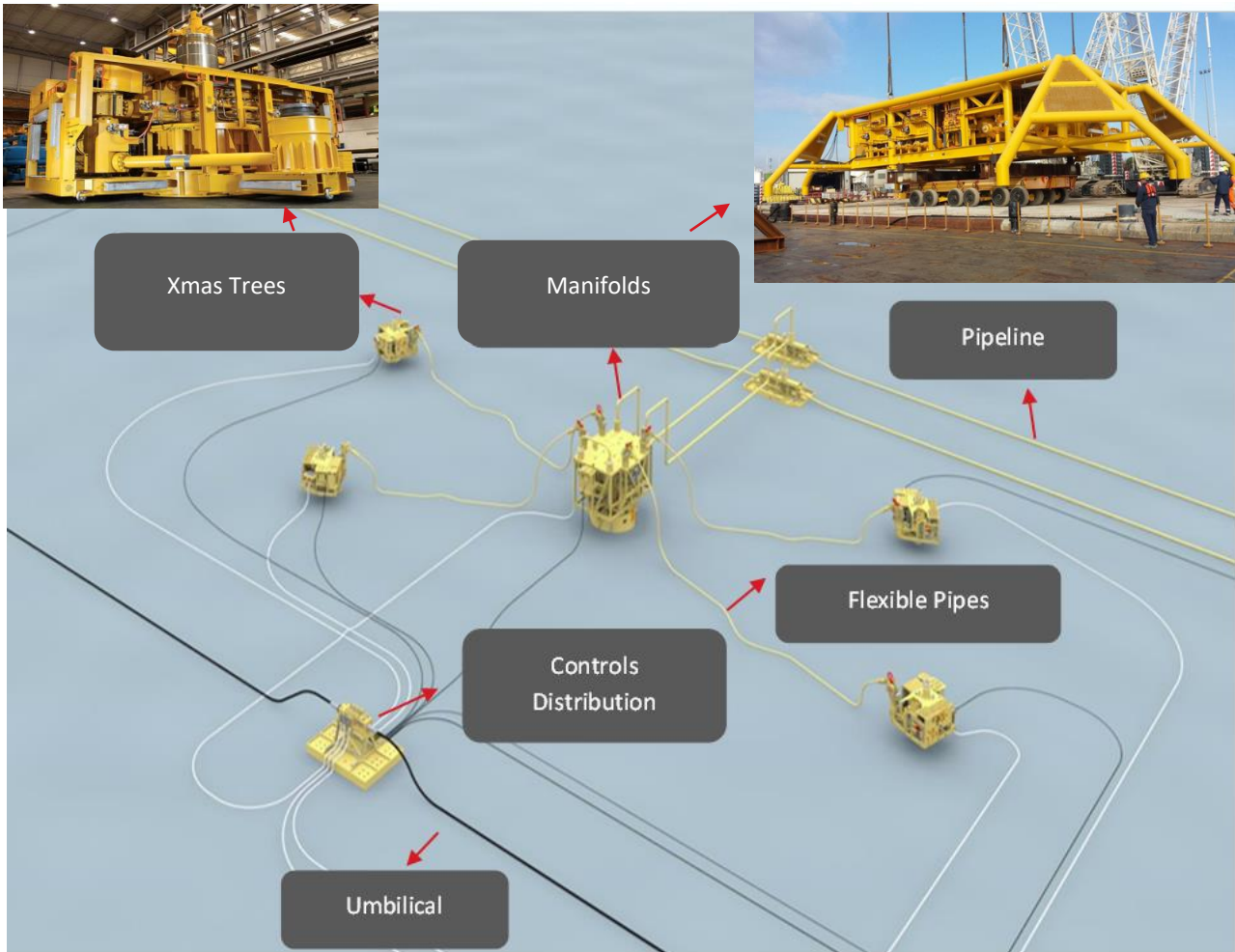
**3.2 Subsea Production System (SPS)**

**3.2.1 General Description**

Sakarya-C26 Gas Field is a large gas reserve with a predicted capacity of 540 bcm, located approximately 165 km offshore Black Sea at a depth of about 2,200 m. Tuna-1, Türkali-2 and Türkali-3 are the wells utilized to determine drilling sites.

The production system will be a subsea network that connects 10 production wells (at the end of Phase 1) throughout a 2,173-km<sup>2</sup> region and transfers them to the gas pipelines. Figure 3-11 illustrates the subsea production system.

Title:	<i>Chapter 1 - Introduction; Chapter 2 - Regulatory Framework; Chapter 3 - Project Description</i>	
DocID:	SC26-OTC-PRJ-EN-REP-000005	Classification: Internal
Rev. :	05	Page: 61 of 133



**Figure 3-11: Illustration of Subsea Production System**

**3.2.2 Construction Phase**

**Well Completion and Installation of Xmas Trees (XTs)**

The XTs will be maintained at the Filyos Port before their installation. Site receipt test and pre-deployment test will be performed to ensure that they are operationally ready. They will be protected from corrosion by use of anodes. XTs will be transported to the site by PSV in accordance with the approved procedures.

The XTs will be inserted on the existing wellheads by the mobile offshore drilling ship. The XTs will be operated and tested on-site to ensure integrity with the well heads. Following a successful test, the well completion works will be finalized by installing upper completion gear and subsequent backflow cleaning procedures. The primary goal of the well completion is to prepare the well to produce hydrocarbons through the SPS. Smart completion valves, which can control reservoir zones, will be installed during the upper completion. After the system has been successfully tested, the correct flow will be supplied to the mobile offshore drilling vessel to clean and test the well. The remaining connections will then be completed by the subsea installation vessels to prepare the well for production.

Title:	Chapter 1 - Introduction; Chapter 2 - Regulatory Framework; Chapter 3 - Project Description	Classification:	Internal
DocID:	SC26-OTC-PRJ-EN-REP-000005	Page:	62 of 133
Rev. :	05		

**Installation of a Distribution Manifold and a Subsea Distribution System Components**

Due to the low load-bearing capability of the seabed in the region where the gas production and MEG distribution manifolds will be installed, a foundation for these units will be installed by erecting suction piles at defined locations within the gas production field. Subsequently, the distribution manifolds will be installed on the pre-installed suction piles. The suction pile foundation for production manifold will be approximately 200 tons in weight, 19m in length and 7.5 m in diameter. The suction pile foundation for MEG manifold will be approximately 87 tons in weight, 12 m in length and 6 m in diameter. The supply ships or cargo barges will transport the suction piles to the field. Other components of the SPS will be installed on seabed directly. The heave compensation system will be activated to prevent any impact on installation winch of the crane from wave movements during installation of the equipment onto the seabed. Furthermore, monitoring with a Remotely Operated Vehicle (ROV) will ensure the launched material to be properly positioned.

The location, slope, elevation and coordinates of the distribution manifold will be recorded once it has been placed.

After all components of the subsea distribution system are installed, they will be connected to the XTs and checked.

**Installation of Carbon Steel Pipelines**

Carbon steel pipelines are the assemblies that allow the flow of gas and MEG between the distribution manifold and the OPF.

Pipelines shall be terminated on seabed with pipeline termination units, which shall be connected to corresponding built-in hubs on the distribution manifolds with tie-in spools. Installation of tie-in spools will be by use of special tools, driven by hydraulic power by the ROV. The ROV will continuously monitor the operation to ensure that the tie-in spools are in the proper position and aligned with the pipeline system. The seal tests will be done after the tie-in spools are installed and connected to check that the gaskets in the joint are properly sealed.

**Other Seabed Foundations**

Prior to installation of other key subsea production system components, such as control distribution units, umbilical termination units, and similar, the mudmats will be located on seabed as foundation. Mudmats are the flat steel structures used as base for these units.

**Installation of Flexible Pipes**

The gas produced will be transferred from the XT to the distribution manifolds by means of flexible pipes. Similarly, the MEG that will be supplied to the production wells will be transported by flexible pipes from the MEG distribution manifold to the XT. Flexible pipes will have flanged joint ends. The heavy construction vessels will undertake the installation.

The flexible pipe interface consists of standard flanged end joints, pre-connected flexible pipes, externally inserted vertical connectors as well as hoisting interface and gooseneck assemblies. Gooseneck assemblies will be stored and transported separately from the flexible pipe. During assembly, they will be connected to the flexible ends in the piping tower of the assembly ship.

Title:	<i>Chapter 1 - Introduction; Chapter 2 - Regulatory Framework; Chapter 3 - Project Description</i>	Classification:	Internal
DocID:	SC26-OTC-PRJ-EN-REP-000005	Page:	63 of 133
Rev. :	05		

Once the first end has been attached to the gooseneck flexible pipe, the flexible pipe will be laid on the seabed by using a reel lay system. When all the flexible pipe has been laid, the second end of the flexible pipe interface will be attached to the second gooseneck and laid on the sea bottom. The first end of the pipe will then be attached to the production distribution manifold and the dispatch end to the wellhead valve. Flexible piping activities will be checked by the ROV to be launched to the sea by support vessel. This will ensure that the laid flexible pipe remains inside the designated construction corridor. Final joints will be undertaken by using a subsea connection system.

**Installation of Umbilical**

The umbilical will be utilized to supply hydraulic fluid and necessary chemicals to the XT. Additionally, cables inside the umbilical will ensure the electrical and fibre optic connection between the land and the sea section of the Project as well as the management of the production system from land.

The installation of the main umbilical begins with the umbilical pulling activities on the shore. The dynamic positioning system will be used to maintain the position of the umbilical lay vessel. The ROV will monitor the umbilical installed on the seabed, and the corridor in which it is located will be controlled, as in pipeline installation case. To maintain the umbilical integrity throughout installation operations, tensional load readings and extension length will be continually monitored.

The umbilical in the production field will be installed in the same method as the main umbilical. The umbilical will be connected to the wellhead valves and seabed distribution manifolds following the completion of the installations.

**Pre-commissioning Activities**

Prior to commissioning, the structural integrity of the pipelines will be determined by flooding, cleaning and gauging activities in which the pig train will be launched and propelled with filtered and treated seawater. After the gauge plate acceptance, the flooding, cleaning and gauging (FCG) operation will be completed. Subsea flooding spread will be operated from support vessel. For hydrotesting (H), subsea hydrotest pump will be engaged and the pipeline will be pressurized. Stabilization period (2 hrs) will start followed by hold period (8hrs). After validation of the hold period, the pipeline will be depressurised to ambient pressure. Subsea leak test which is similar to hydrotesting will follow afterwards. After FCG-H activities, nitrogen purging is applied. When the MEG pipeline is filled with MEG-Cl mixture, the treated seawater between the MEG distribution manifold and the wellhead valves will be propelled towards the wellhead valves and pushed out of the system.

Discharges related with pre-commissioning activities are presented in Chapter 3.8.1.

**3.2.3 Operation Phase**

The main parts of the production system planned to be installed on the subsea are

- the horizontal XT valves placed on top of the wellheads where production control and measurement connections for each well are made, and
- the distribution manifolds placed to collect and control the produced gas flow coming from wells and transfer it to the gas pipeline.

Title:	<i>Chapter 1 - Introduction; Chapter 2 - Regulatory Framework; Chapter 3 - Project Description</i>	Classification:	Internal
DocID:	SC26-OTC-PRJ-EN-REP-000005	Page:	64 of 133
Rev. :	05		

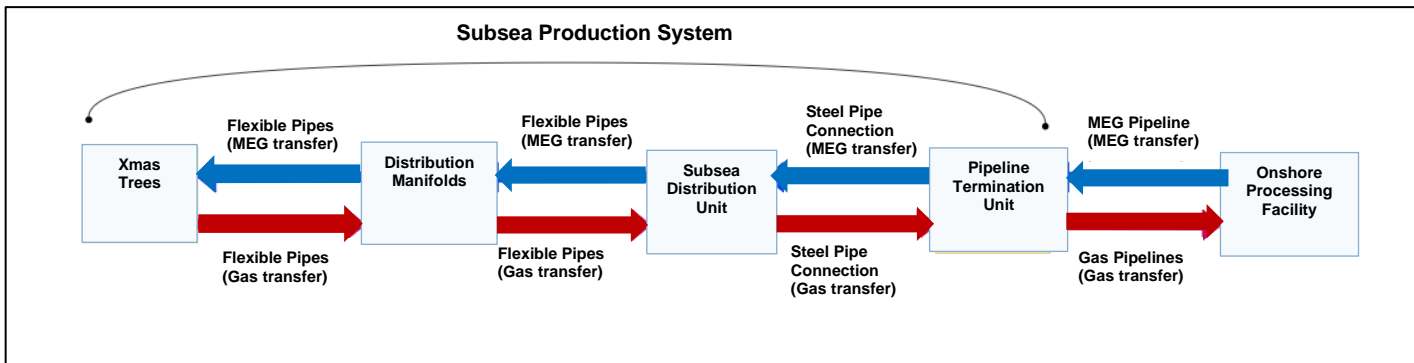


The XTs located at each wellhead location allow controlling the wells. The XTs will be connected to the production distribution manifold with flexible pipes. The flexible pipes will deliver both the gas and the MEG.

The hydraulic fluid, electrical and fibre optic connection cables within umbilical will be used to control valves in the production system and to ensure the safe flow of gas. The system will extend from the onshore production facility to the production.

MEG will be comingled with the gas during the transportation of the produced gas to land through gas pipeline in order to prevent the formation of hydrate, which may clog the pipe due to pressure and temperature fluctuations. The MEG will be transported to the production site through a pipeline (about 10 inches - 25.4 cm - in diameter) from land and infused into the gas by injecting it into the well heads. Thereafter, it will turn back to land mixed with gas through the gas pipeline.

Figure 3-12 provides the flow process chart of the subsea production system.



**Figure 3-12: The Flow Process Chart of The Subsea Production System (Source: EIA Report)**

### 3.3 SURF

#### 3.3.1 General Description

Within the Phase 1 of the Project the SURF will include:

- A seabed umbilical, approximately 6 inches (15.24 cm) in diameter that bundles together small pipes containing fluids, chemicals, and electrical and fibre optic lines;
- Gas pipeline, 16 inches (40.64 cm);
- The MEG line approximately 10 inches (25.4 cm) in diameter.

The details and schedule of the SURF component of the Phase 2 has not been finalized yet.

#### 3.3.2 Construction Phase

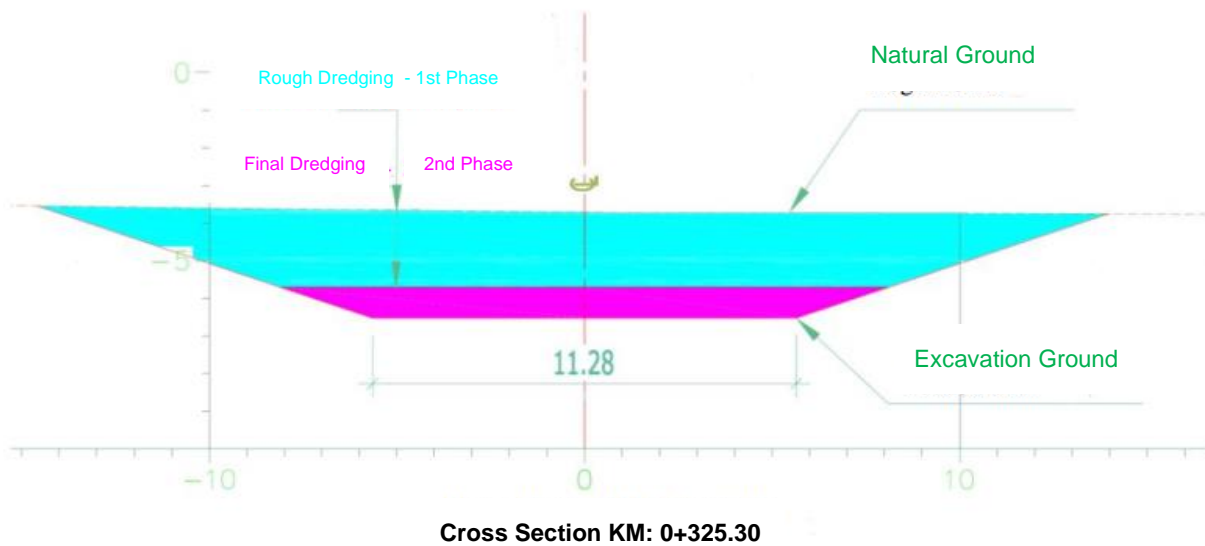
##### Laying in shallow water section (Shore Crossing Sections) from shoreline to 20 m depth (KP 0 - KP 1+470)

For laying of the pipeline in the shallow water section, a 3 m trench will be excavated in the planned pipeline corridor for an overall length of 1.4 km from the shore till approximately 20 m depth. Umbilical will be buried under seabed by post lay trenching method at approximately 30 m east of the gas pipeline. The sediments excavated will be temporary deposited on a dumping site, covering a surface of 0.26 km<sup>2</sup>, located close to the

Title:	Chapter 1 - Introduction; Chapter 2 - Regulatory Framework; Chapter 3 - Project Description	Classification:	Internal
DocID:	SC26-OTC-PRJ-EN-REP-000005	Page:	65 of 133
Rev. :	05		

port having minimum 5 m and maximum 14 m depth. Once the pipelines which will be previously coated in concrete have been laid, the trench will be backfilled with the excavated sediments, covering the pipeline by a minimum of 2 m. The expected time for this work is 50 days for the dredging and additional 55 days for the backfilling (movement of sediment from the temporary dumping area to the trench).

Dredging is basically handled in two stages. Stage 1 is called "Rough Dredging" with a thickness of 2.0~2.5 m. The thickness of the Stage 2, "Final Dredging" after rough dredging, can vary between 0.5 and 1.0 m depending on the soil type. As presented in Figure 3-13, the purpose of dredging in two stages is to carry out precise excavation in the final stage.



**Figure 3-13: Dredging Stages**

Between two stages an Interim Bathymetric Survey shall be carried out by Survey Boat to get more accurate data and provide certain depths to be excavated in final stages. After Final Dredging a Final Bathymetric Survey shall be performed to see final elevations are appropriate to design levels or not. If any section of the trench is not convenient to desired level, the dredger shall be positioned to that section to make additional excavation again.

Before the construction of the shore crossing section begins, the access routes and passageways will be prepared, the site will be arranged and levelled, piping equipment and temporary field facilities will be installed.

The dredging technique in the shore crossing section will vary depending on the water depth, soil conditions and the embedding depth of the umbilical and pipelines. The vessel with backhoe mechanism will be utilized during the ditching activities in the coastal crossing section up to a water depth of 5 m. An excavator will be utilized at the locations close to the land. A 500-meter safety zone will be established for the vessels that will be working in ditching activities.

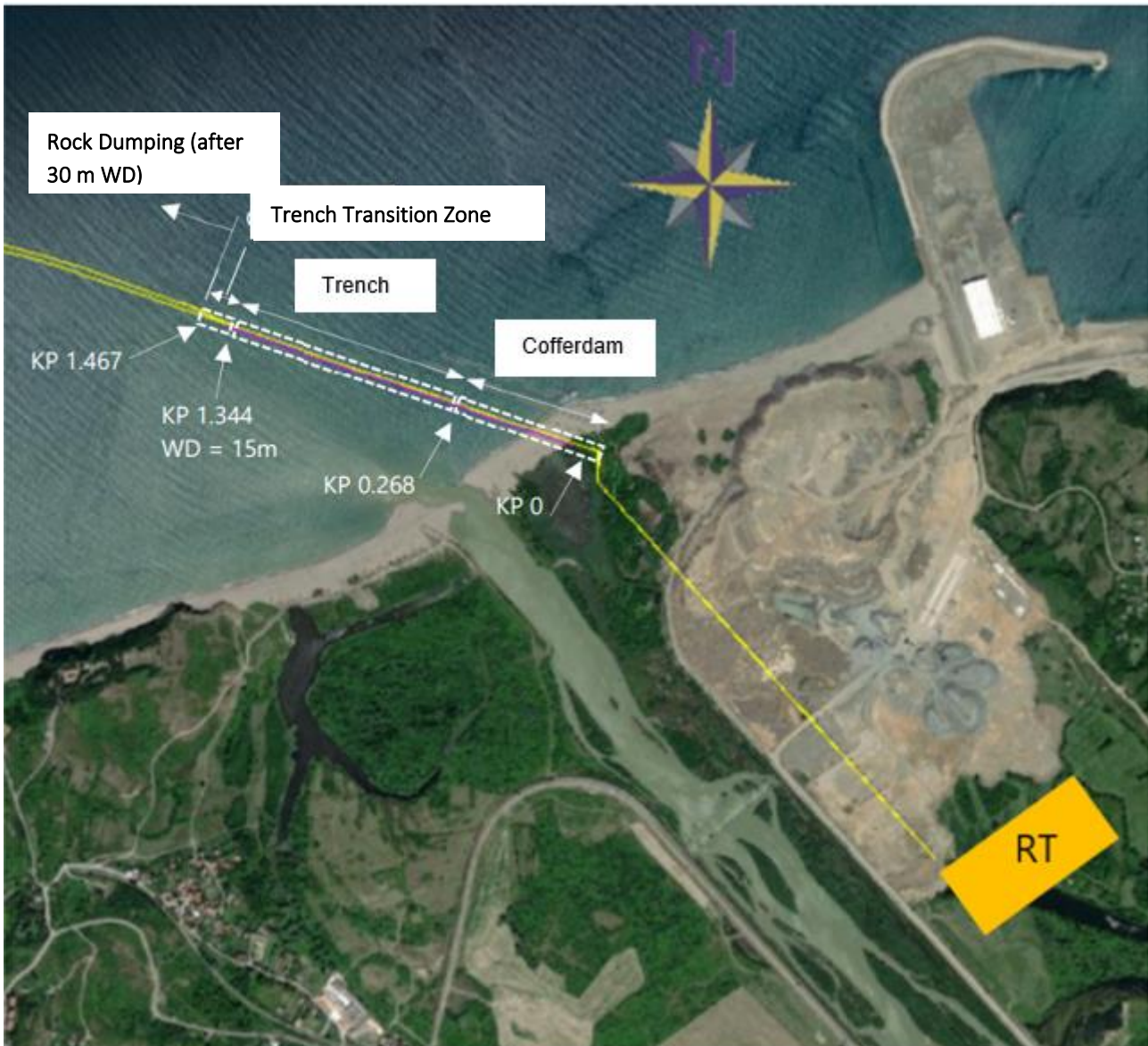
The dredging activity will be carried out only on the route of the pipelines within an area of approximately 1,470 m x 3 m, and the estimated amount of the excavated soil has been calculated as 81,356 m<sup>3</sup>.

Title:	Chapter 1 - Introduction; Chapter 2 - Regulatory Framework; Chapter 3 - Project Description	
DocID:	SC26-OTC-PRJ-EN-REP-000005	Classification: Internal
Rev. :	05	Page: 66 of 133

The scope of landfall and shore crossing section trenching is as follows:

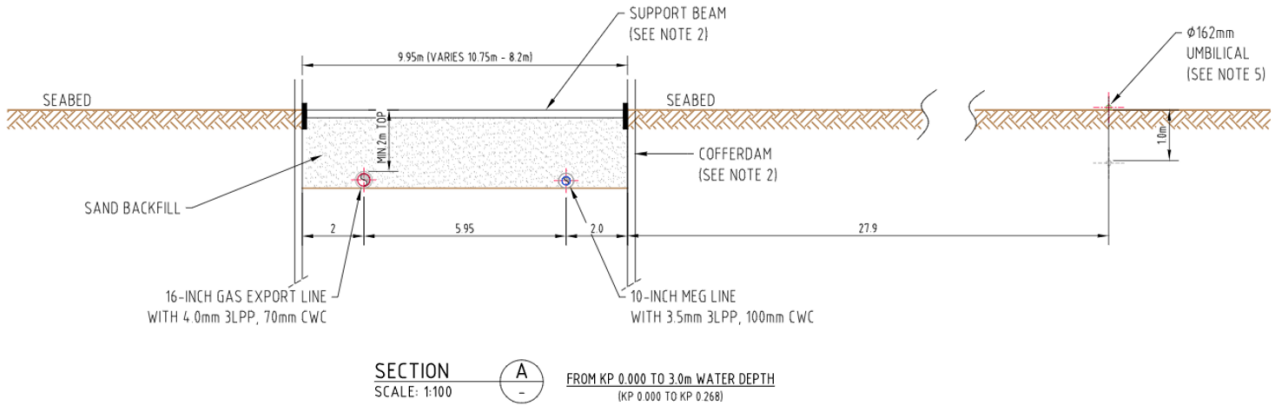
- Cofferdam between KP 0 – KP 0+268 (water depth 3 m). The sediment excavated in this shallow water zone will be temporary placed onshore.
- Trench KP 0+268 – KP 1+344 (water depth = 15 m)
- Trench crossing zone between KP 1+344 – KP 1+467 (water depth 17.1 m)

An overview of the coastal and coastal crossing section routes within the scope of the trenching activity is presented in Figure 3-14.

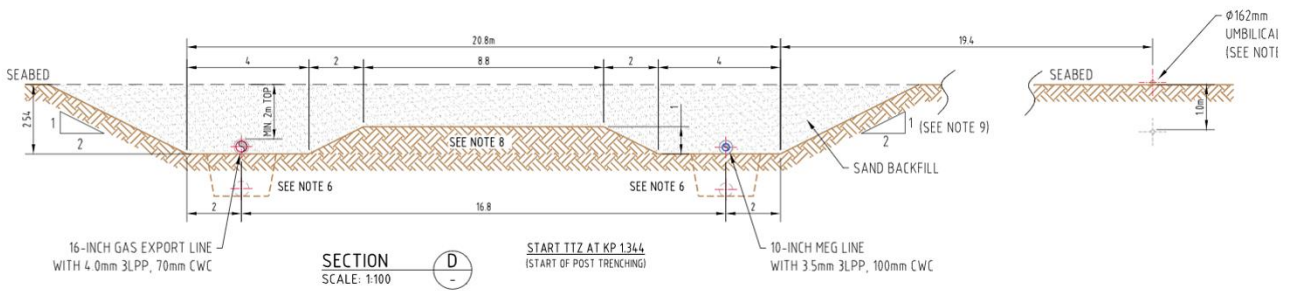


**Figure 3-14: Overview of Coastal and Coastal Crossing Section Routes**

Title:	Chapter 1 - Introduction; Chapter 2 - Regulatory Framework; Chapter 3 - Project Description	Classification:	Internal
DocID:	SC26-OTC-PRJ-EN-REP-000005	Page:	67 of 133
Rev. :	05		



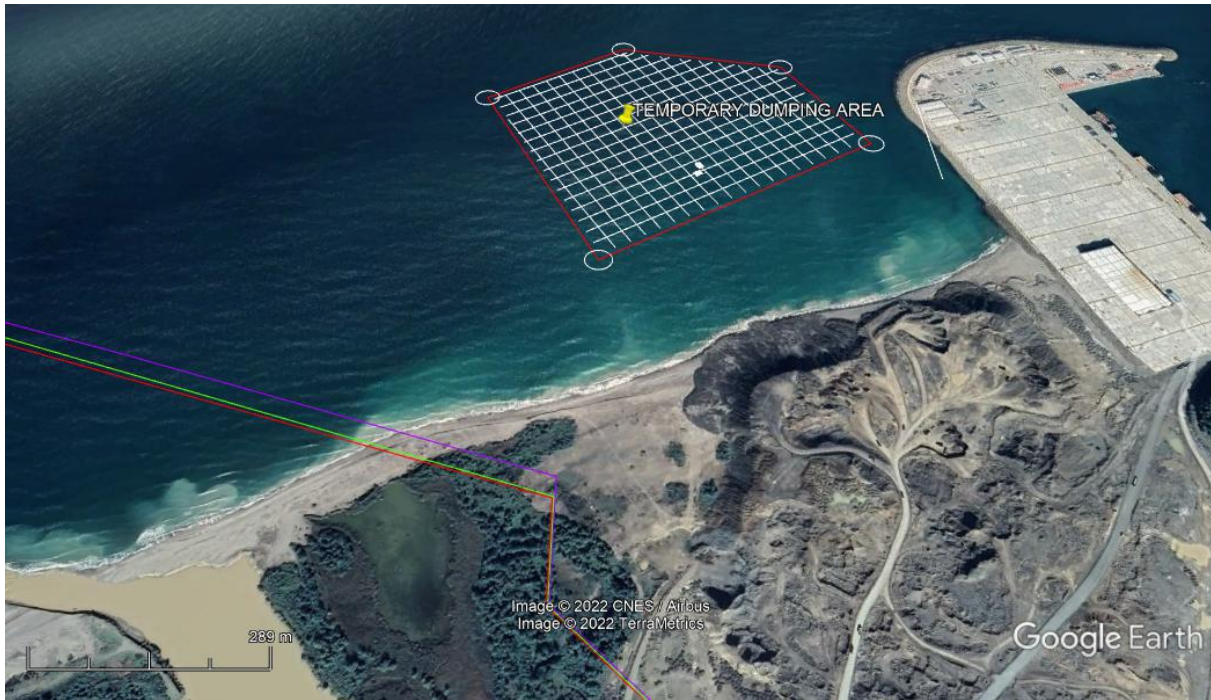
**Figure 3-15: Coastal Crossing Profile - Schematic Trench Width (KP 0 – KP 0+268 (water depth 0-3 m))**



**Figure 3-16: Coastal Crossing Profile - Schematic Trench Width (Trench Transition Zone at KP 1+344)**

The excavated sediment during the dredging activities will be stored in a temporary dumping site shown in Figure 3-17 and utilized to close the trench when the process is completed.

Title:	Chapter 1 - Introduction; Chapter 2 - Regulatory Framework; Chapter 3 - Project Description	Classification:	Internal
DocID:	SC26-OTC-PRJ-EN-REP-000005	Page:	68 of 133
Rev. :	05		



**Figure 3-17: Satellite Image Showing the Temporary Dumping Area**

The cofferdam will be used to reduce the risk of sediment flow from Filyos River into the trench. Figure 3-18 provides a typical cofferdam example. Causeways must be built by raising protective barriers (tubular piles) against the waves on both sides of the ditch made of stones and rocks imported to the site from outside to protect the ditch that has been dug on near shore of coastal crossing by using an open excavation technique (with or without cofferdam, in either case) from sea movements. The cofferdam is planned to be built on land from KP0 to KP0+268 with a water depth of 3 m. Two rows of cofferdams will form the side walls of the ditch. Soil type, groundwater and environmental conditions will determine the design of these temporary supports. In addition, outriggers can be placed along the trench to provide support against lateral pressures. For lateral strength, an additional cofferdam row can be created and the space between the cofferdam rows filled with excavation material/soil. The internal excavation of the cofferdam, where the pipeline will be laid along this 268 m line, will be completed using land equipment. Excavation will be carried out using an excavator from both sides of the cofferdam on the land side, and over the temporary passage/work road to the southwest of the cofferdam on the seacoast.

Title:	<i>Chapter 1 - Introduction; Chapter 2 - Regulatory Framework; Chapter 3 - Project Description</i>	Classification:	Internal
DocID:	SC26-OTC-PRJ-EN-REP-000005	Page:	69 of 133
Rev. :	05		

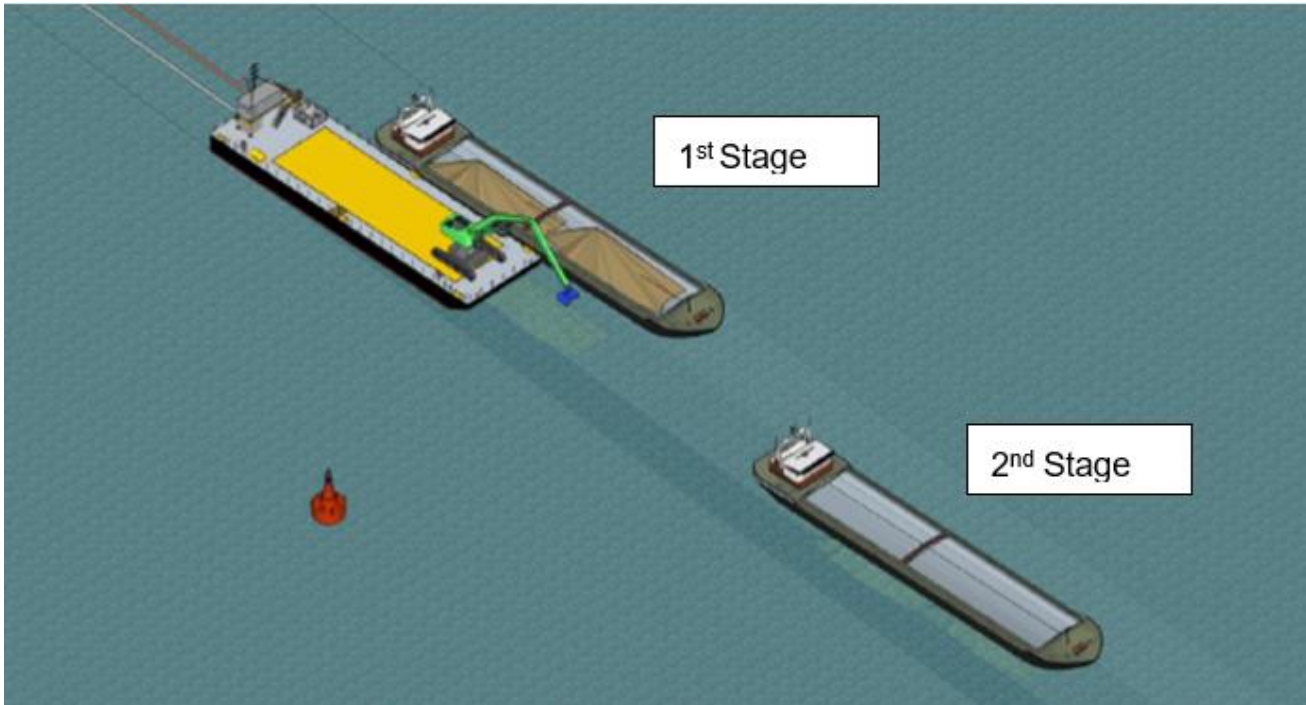


**Figure 3-18: A Typical Cofferdam (Source: EIA Report)**

The pipe joints are welded on a pipelay barge moored offshore and an onshore winch is used to progressively bottom-pull a joint length pipe string towards shore from the barge via a steel wire pull wire, as additional joints are welded to the pipe string on the barge. The first joint is capped with a pulling head and pull line running to shore is attached to a winch. When the first weld behind the pipeline pull-head reaches the onshore tie-in location, the barge begins to move offshore in the conventional pipelay mode, as welding on the barge continues. Each completed joint weld will be fully inspected, both visually and by Automatic Ultrasonic Testing

The umbilical will be pulled from the installation vessel located in approximately 15m water depth to the OPF an overall distance of approximately 2.7 km. The umbilical will be floated, using small buoyancy modules, and pulled up to the beach where the divers will remove the floats. Following the pulling activities of the umbilical and pipelines at the coastal crossing section have been completed, the shore base pulling spread will be removed, the cofferdam will be backfilled and removed, the ditches trenches will be closed with the stored sediment excavated during the construction operations. In order not to disturb the axis of the pipes, the filling works will be carried out in two stages, similar to the dredging works. For marine spread filling, the backhoe dredge will be placed in the area where the dredged material is stored at sea and the material will be loaded onto the bulk vessels. For the first stage of backfilling, approximately 50 cm of backfill material will be placed over the pipelines along the trench using the excavator/material holder placed on the barge. In the second stage, the dredged material will be placed in the dump vessels and the material will be discharged into the trench. After the dredged material is loaded, the bulk vessels will pass through the trench as shown in Figure 3-19.

Title:	Chapter 1 - Introduction; Chapter 2 - Regulatory Framework; Chapter 3 - Project Description	Classification:	Internal
DocID:	SC26-OTC-PRJ-EN-REP-000005	Page:	70 of 133
Rev. :	05		



**Figure 3-19: Backfill Process**

If the excavated sediment stored is insufficient, stability studies will be carried out by importing stones from appropriate quarries. Furthermore, upon assessing the risks of interaction with third parties, the material supplied by the licensed quarries may be utilised to close the ditch or the pipeline sections that remain outside the ditches. To this end, the “Technical Principles of Planning and Design of Coastal Structures” published by the General Directorate of Infrastructure Investments will be followed in selecting the stones to be utilised as the filler.

The work between KP 0 – KP 0+268 involves the use of an excavator for constructing cofferdam and storing excavated material by using it as a work road for itself. The work between KP 0+268 and KP 1+470 involves the use of 7 boats (Split Hopper Barge, DP Deck Cargo Ship, Backhoe Dredger, Tugboat and Service Boats) for dredging, towing, laying the pipe and surveying. Typical mages of vessels are provided in Figure 3-20. A number of guide rollers will be deployed along the land route leading to the onshore production facility. These will be utilised to deploy the towing crane.

Title:	Chapter 1 - Introduction; Chapter 2 - Regulatory Framework; Chapter 3 - Project Description	
DocID:	SC26-OTC-PRJ-EN-REP-000005	Classification: Internal
Rev. :	05	Page: 71 of 133



**Figure 3-20: Typical Images of Vessels to Be Used at Near Shore Dredging**

The materials are anticipated to be transported from the Filyos Port to the construction site of the coastal crossing section by barges or by trucks. The quarry to use (if necessary) is close to the site. Security zones will be established to prevent unauthorized access of vessels or persons to the construction site during both ditching and the construction of the coastal crossing section.

In the event that the excavated excess sediment that may be generated due to any reason during the construction/installation of pipelines and seabed umbilical will be dumped into an existing nearby dumping site or another location on the seabed designated by the Republic of Turkey Ministry of Environment and Urbanization, the requirements of the “Regulation on the Environmental Management of the Dredged Material” will be met upon request by the Ministry.

**Laying in offshore section from 20 m depth onward (KP 1+470 – SPS)**

Gas and MEG pipelines will be laid by similar methods from shore to offshore. The pipeline will be transported by offshore piping barge from where it was temporarily positioned by the shallow water piping barge. Priority temporary piping heads will be removed on the barge. As the pipe welding and coating is completed, the piping will be resumed. The offshore piping barge will engage the dynamic positioning system to fix itself. It will undertake piping activities in parallel with welding and coating works.

The location where the pipeline laid on the seabed will be controlled by ROV launched into the sea through auxiliary ships. This will ensure that the laid pipe remains inside the designated construction corridor. Several piping parameters will be checked during the piping activities. After the completion of the piping activities, a pipeline termination unit will be inserted on the pipe end, extending to the subsea production system. This will connect the pipeline to the production distribution chamber once the construction operations of the sea section are completed.

Title:	<i>Chapter 1 - Introduction; Chapter 2 - Regulatory Framework; Chapter 3 - Project Description</i>	Classification:	Internal
DocID:	SC26-OTC-PRJ-EN-REP-000005	Page:	72 of 133
Rev. :	05		



The piping barge will intervene after the piping activities to avoid any damage to the pipelines and the umbilical laid on the seabed caused by third-party activity (anchoring, fishing activities, etc.). Two alternative intervention methods are planned: (1) the soil beneath the umbilical and pipelines shall be mechanically excavated to allow them to be embedded into the seabed, (2) the umbilical and pipelines shall be covered with gravel to provide protection against external factors.

Where there are gaps due to roughness on the seabed beneath the pipes and umbilical laid on the seabed, there may be interventions on the seabed after the piping activities to ensure the safe operation of the umbilical and pipelines in long-term. Two alternative methods can be employed to that end: (1) the voids beneath the umbilical and pipelines can be filled with gravel or mechanical supports (2) the seabed elevation differences shall be rectified to allow umbilical and pipelines to subside on the seabed.

Following the completion of the ongoing marine surveys and the development of the design, the requirements and techniques of seabed intervention will be finalized.

The work involves the use of deep water pipelay barge, pipe supply vessel, cargo barges, crew boats.

**Pipeline Protection**

MEG and gas pipelines will be protected against corrosion with at least 3 mm thick 3LPP (3 times polypropylene) to be coated outside the pipes. The 3LPP coating is composed of 3 different layers, is resistant to high operating temperatures and provides mechanical protection in addition to corrosion protection. The pipelines will additionally be protected by the sacrificial anode, which will be placed on the pipes as often as the design requires. The design and engineering calculations of the sacrificial anodes will follow the DNV RP 103 standard that examines sea pipelines. The corrosion inhibitor that will be delivered from the onshore production facility through the umbilical, as well as the corrosion clearance of 3 mm in the pipeline wall thickness, will ensure corrosion protection in the pipelines.

**Pre-commissioning Activities**

Following the completion of the construction stage, a number of procedures will be followed to verify that the lines operate smoothly in the expected circumstances. These procedures will confirm that the umbilical and pipelines were installed as planned, that gas was transmitted at the planned operating pressure, and that all other design criteria were met smoothly. The procedures to be followed during the pre-commissioning stage are outlined below.

Flooding, Cleaning, Gauging and Hydrotesting (FCG-H)

Prior to commissioning, the structural integrity of the subsea system is determined by FCG-H activities which involves following activities:

**Free Flooding:** Due to seabed profile and extensive water depth at field, free flooding of trunklines (gas and MEG) is required to keep pig train velocity and acceleration within standard parameters. Indeed, water column at the back of the pig train would increase rapidly according to seabed profile if no water is in front of pig train to counterbalance pressure at the back. Free flooding will be operated from Offshore field at Pipeline End Termination (PLET) and the trunklines will be filled with filtered seawater until pressure equalization is reached

Title:	<i>Chapter 1 - Introduction; Chapter 2 - Regulatory Framework; Chapter 3 - Project Description</i>	Classification:	Internal
DocID:	SC26-OTC-PRJ-EN-REP-000005	Page:	73 of 133
Rev. :	05		

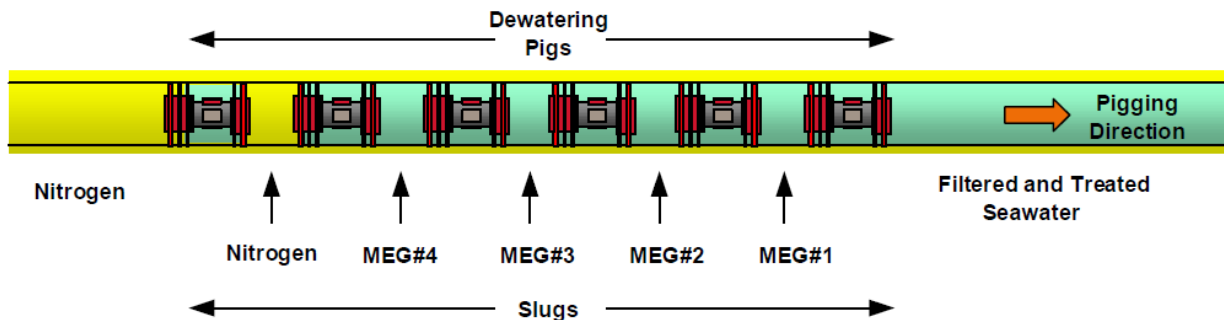
FCG: FCG spread will be operated from Terminal that will be located at onshore. During the initial cleaning, cleaning pig is loaded in an onshore temporary Pig Launcher Receiver (PLR) and it will be launched and propelled by filtered and untreated seawater until its reception to subsea pig cage at PLET location. During the final cleaning, cleaning pigs will be launched in sequence with 50 linear meters between each other. Last cleaning pig of the pig train will be propelled by filtered and treated dyed seawater (with RX-5255, a mixture of corrosion inhibitor, biocide, oxygen scavenger, leak detection dye) until its reception to subsea PLR at PLET location. After the gauge plate acceptance, the FCG operation will be completed.

Hydrotesting: Hydrotesting spread will be operated from Terminal that will be located at onshore. High pressure hoses are connected to testing head at onshore and pressurization is initiated. Stabilisation period (6 hrs) will start followed by the hold period (24 hrs). After validation of the hold period, the trunkline will be depressurised to atmospheric pressure. All system except Production Trunkline will be subject to global leak testing which is similar to hydrotesting.

Discharges related with FCG-H activities are presented in Chapter 3.7.2.4.

Nitrogen Dewatering, MEG Swabbing and Packing of Gas Pipeline

Nitrogen dewatering spread will be operated from Terminal at the PLR Onshore. After FCG-H activities the line is full of filtered and treated seawater. Dewatering pig train composed of a number of pigs injected MEG between each of them are launched through the line. Nitrogen is injected before the last pig until reception of dewatering pig train at receiving side (PLET). Trunkline will be left packed with Nitrogen at the operating dewatering pressure.



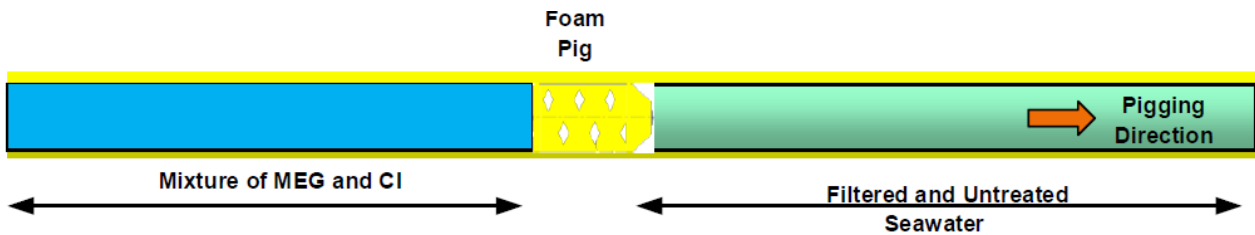
**Figure 3-21: Pig Train Configuration for Gas Trunkline During Nitrogen Dewatering**

Discharges related with Nitrogen dewatering and MEG swabbing activities are presented in Chapter 3.7.2.4.

Filling the System with MEG

After all leakage testing on the MEG pipeline has been accomplished, the treated and filtered seawater will be replaced with MEG and CI mixture (85/15). MEG pumping spread will be located at the CLC side to deliver the mixture of CI and MEG from the CLC to the Terminal using temporary hose/pipeline system. MEG and CI mixture will be supplied from the PLR onshore to propel the seawater inside the MEG pipeline towards the MEG distribution chamber.

Title:	Chapter 1 - Introduction; Chapter 2 - Regulatory Framework; Chapter 3 - Project Description	Classification:	Internal
DocID:	SC26-OTC-PRJ-EN-REP-000005	Page:	74 of 133
Rev. :	05		



**Figure 3-22: Pig Train Configuration for MEG First Fill**

Checking Umbilical

In all umbilical there is two different types of lines; hydraulic lines (LP, HP and spare) and chemicals lines (MeOH, SI). All umbilical will be tested for hydraulic, electrical and fibre optics to verify that they are not damaged before starting operation. It will be monitored for pressure change and electrical continuity to identify any damage that occurs during installation. Finally, the connections of the OPF will be tested together with the control room.

Works at the End of the Construction

After all installation and pre-commissioning activities have been completed, surveys will be undertaken to assess the condition of the seabed components at the end of the installation. These surveys will provide a background value for future work. Sea surveys will be conducted with a magnetometer to pinpoint the location of the umbilical and pipelines for the embedded sections. Unembedded sections such as the seabed umbilicals, pipelines, and connectors will be visually inspected, and their final position and slope data will be documented. All data gathered will be reflected in the reports at the end of construction.

**3.3.3 Operation Phase**

The maintenance operations to be conducted during the operating phase of the Project aim to investigate all possible impacts on the pipeline, ensure the safety of personnel, goods and the environment, determine the situations that may obstruct safe and regular natural gas flow, minimize repairs, monitor all incidents based on the cause-and-effect relationship principle for the operations to be conducted during the operating phase.

Since the pipelines are strategically important for the project, conducting the maintenance-repair operations during the operating phase regularly is essential. The planimetry of the pipelines, filling or emptying of the pipeline bottom due to natural causes and/or pipe and marine bottom profile due to the pipe motions as a result of the marine bottom motions, free moving distances of the pipelines, any kind of natural or superficial event that may affect the pipeline, sea bottom motions in seismic or landslide zones, local or larger damages occurred on the external surface, the status of the previous stabilization applications will be checked continuously. The inspections to be performed including the inspection of outer and inner pipeline surfaces are explained in the following sections.

**Outer Inspections**

The scope of the pipeline outer inspections will be determined depending on the line risk analysis, impair and the way of impair of the mechanisms, the results of the previous inspections, measurement limits and accuracy of the control system, and changes in the pipeline operating parameters. The coastal transition section, steep slopes, critical zones like places where tidal movements are observed will be inspected more frequently. ROV

Title:	Chapter 1 - Introduction; Chapter 2 - Regulatory Framework; Chapter 3 - Project Description	
DocID:	SC26-OTC-PRJ-EN-REP-000005	Classification: Internal
Rev. :	05	Page: 75 of 133

and sonar scanning methods will be used during the inspections. Table 3-4 shows the inspections, estimated frequencies and durations. The frequencies of inspections may vary depending on the design requirements and durations may vary depending on the climate conditions.

**Table 3-4: Outer Inspection Operations**

Name of Operation	Inspection Frequency	Inspection Duration
Inspection of Critical Sections	Annually	2 weeks
Inspection of the Cathodic Protection	Annually	2 weeks
Inspection of the Multi-Beam Echosounder	Annually	2 weeks (to be performed during the inspection of the critical sections)
Inspection of the Pipeline Location and Levelling	Once every five years	2 weeks
Inspection of the Valves	Annually	3 days

### Inner Inspections

The pipeline inner inspections will be performed by using PIG. The status of the inner section of the pipes will be checked via the sensors over PIG. The initial inspection will be carried out during the pre-operation phase. The operations to be carried out during the operating phase will be determined according to the design requirements and are planned to be carried out once every five years. Within the scope of the inspections, the pipeline thickness will be measured, and the pipeline will be located.

If planned, the necessary permissions will be obtained for the major repair operations to be performed in the offshore section. Other inspections to be carried out are shown in the table below.

**Table 3-5: Other Inspection Operations**

Name of Operation	Foreseen Inspection Frequency	Inspection Duration
Replacement of the Hydraulic Connection Cables and Electrical Connection Cables	Once every twenty years	1 weeks
Chemical Injection	Once every twenty years	1 weeks
Replacement of Anode Plates	Once every twenty years	2 weeks

## 3.4 Onshore Production Facility (OPF)

### 3.4.1 General Description

The Onshore Production Facility (OPF), which will be built on the onshore section of the Project, mainly intends to process the raw gas from the Sakarya Gas Field. At the facility to be established on the land side; water and liquids will be separated from the gas flowing from the reservoir, particles will be filtered, the humidity will be absorbed, and gas will be compressed and transported to the network.

Title:	<i>Chapter 1 - Introduction; Chapter 2 - Regulatory Framework; Chapter 3 - Project Description</i>	Classification:	Internal
DocID:	SC26-OTC-PRJ-EN-REP-000005	Page:	76 of 133
Rev. :	05		

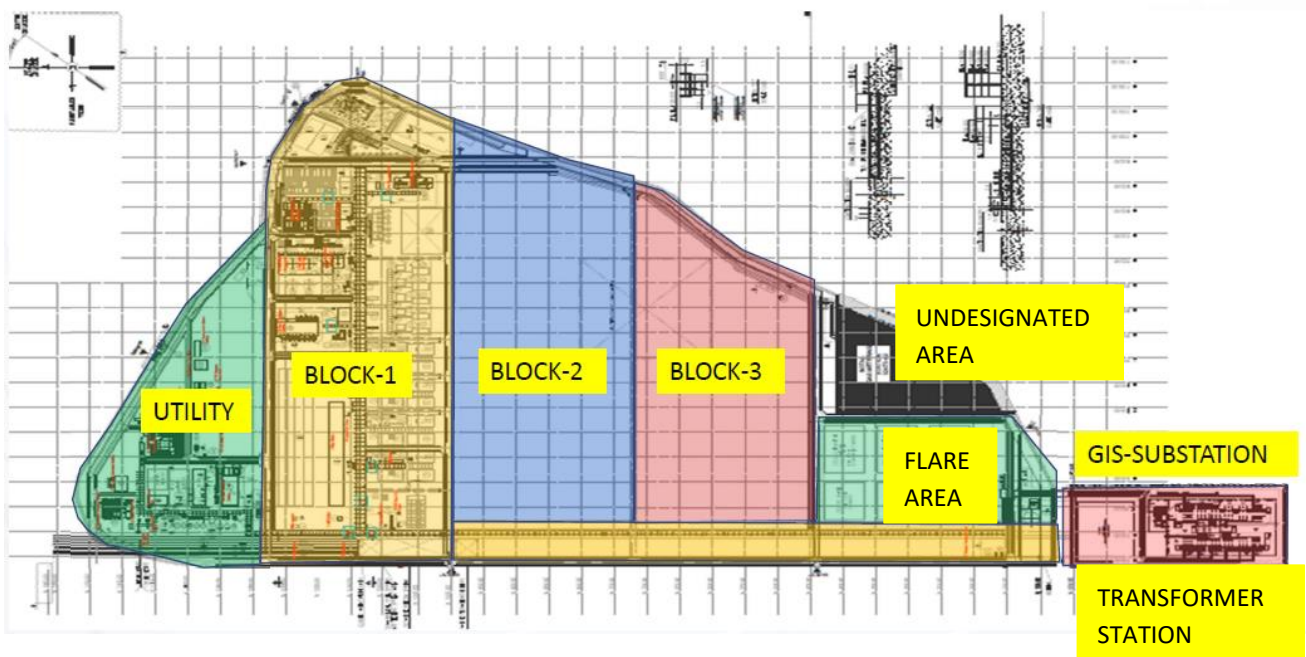
The OPF is planned to be built in two phases. Phase 1 will begin operations in 2023, while Phase 2 will be operational at a later period after 2023. Phase 1 will be capable of processing natural gas of a maximum of 10 million standard m<sup>3</sup> per day (with the addition of Phase 2, OPF will have a total processing capacity of 40 million standard m<sup>3</sup>).

The OPF will comprise of a 10 million SCMD process train for Phase 1 and a 30 million SCMD process train for Phase 2. Total OPF facility capacity is 40 million SCMD (target of Phase 1 and 2).

**3.4.2 Construction Phase**

The OPF will be divided into 3 has processing blocks (Figure 3-23). Block 2 is designated as temporary storage of excavation waste and Block 3 is designated as construction camp area for Schlumberger (Contractor). Installation of pipe racks from Block 1 to Flare Area will be done during the Phase 1. Each block has its own flare.

There is no topsoil present at the OPF area due to industrial zone construction activities and ongoing soil improvement works.



**Figure 3-23: OPF Planning**

The OPF is generally designed with a modular approach. The facility would be modular except for large units such as mass liquid retainers. The modular units would reduce the number of accidents that occur during the construction stage. It will also allow for more flexibility in positioning the units and facilitate the replacement of equipment. Modules will consist of “steel construction structural members”, on which process gears, devices, valves, piping components and cables are assembled. The steel construction structural members will be moved to the construction site and assembled with other process units.

The basic construction work will be coordinated as much as possible with the time when the equipment will arrive at the site. The modules will be implanted on the foundations and secured to them.

Title:	Chapter 1 - Introduction; Chapter 2 - Regulatory Framework; Chapter 3 - Project Description	Classification:	Internal
DocID:	SC26-OTC-PRJ-EN-REP-000005	Page:	77 of 133
Rev. :	05		

**Utilization of Local Resources**

At the construction stage, it is intended to maximize the utilization of local resources. This would foster trust and mutual benefit, resulting in a more cohesive relationship for the future and a boost to the local economy. Various local resources, such as materials, services, and manpower, will be employed first and foremost if they are acceptable in terms of availability, requirement, and other qualities.

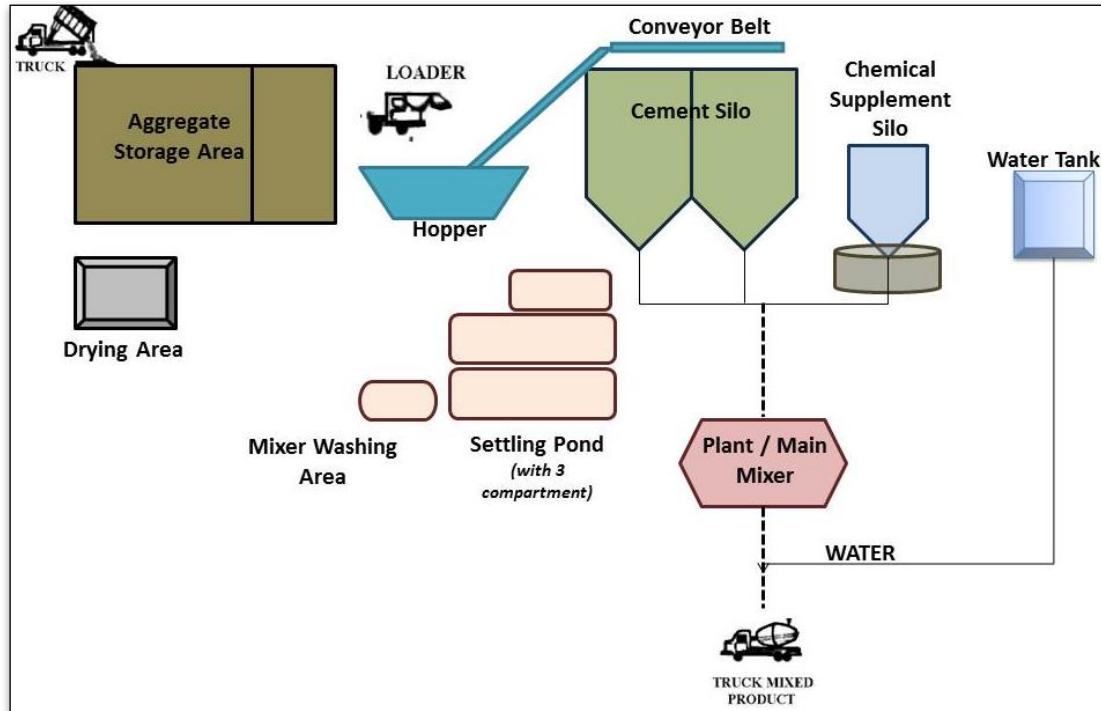
**The Use of Prefabricated and Precast Structures**

A workshop assembly will be accomplished consistent with the process and logistical feasibility and economics to boost business productivity, eliminate idle time at construction sites, and minimize time lag due to weather conditions.

The ground will be prepared, levelled in the construction site, and then the foundation of cast-in-place reinforced concrete will be installed on the prepared ground. Steel structures will be manufactured in fabrication shops at transportable size, then transported to the site and installed. In the pipe workshop, which will be temporarily established at the CLC, the protective layer necessary for pipe reels will be applied. Tanks will be manufactured in the prefabrication shop and transported to the site for field assembly after their first layer (except for the ends) have been painted. The welds will be cleaned and painted according to project specifications after installation and hydrotesting. If the tanks require internal lining, the inner surface will be cleaned, and a protective final coating will be applied after the hydrotest. The tanks will be assembled by the subcontractors of the construction, mainly by crane lifting. As long as the dimensions of the foundation to be erected are suitable, it will be prefabricated in a location designated for this function.

There will be a concrete batching plant having 90 m<sup>3</sup>/day capacity in order to supply concrete required for construction of the onshore facilities. The plant will be located south of the transformer station inside the Project area. Aggregate (with the characteristics of 0-5, 5-12, 12-22 mm) brought by trucks from the crushing-screening plants will be stored in the stock area, cement will be stored in closed silos, and additives will be stored in tanks of 15-20 tons. Concrete will be produced with wet mixed ready mixed concrete technique. All components, including water, are prepared by measuring and mixing at the plant. According to the recipe, the aggregate, water, cement and chemical substances stored in separate sections are weighed in the determined proportions and transferred to the mixer boiler. After mixing sufficiently, it will be discharged into the transmixers for transportation to the required location. Generalized process diagram of the concrete batching plant is presented below.

Title:	<i>Chapter 1 - Introduction; Chapter 2 - Regulatory Framework; Chapter 3 - Project Description</i>	Classification:	Internal
DocID:	SC26-OTC-PRJ-EN-REP-000005	Page:	78 of 133
Rev. :	05		



**Figure 3-24: Generalized Process Diagram of the Concrete Batching Plant**

**Structural Steel Works**

The structural steel works required under the project scope are classified as follows.

- Support steel works for pipe/cable;
- Support steel works for equipment;
- Platforms to be built for ships/equipment;
- Miscellaneous steel works;
- Support steel systems for building;

Prefabrication with bolted joints will be preferable to reduce installation time at the construction site. All structures will be pre-assembled. All work will be scheduled to reduce the number of activities conducted at the construction site.

**Equipment Assembly Works**

The equipment required under the project scope is classified as follows.

- Static Equipment
- Rotary Equipment
- Package Equipment

Title:	Chapter 1 - Introduction; Chapter 2 - Regulatory Framework; Chapter 3 - Project Description	Classification:	Internal
DocID:	SC26-OTC-PRJ-EN-REP-000005	Page:	79 of 133
Rev. :	05		

Each piece of equipment mentioned above will be manufactured/produced according to the design and will be inspected and tested in full conformance with local and national laws, procedures and any applicable technical codes.

Most of the equipment and supplies will be transported to the construction site after being manufactured in the supplier plant by inserting covers or plugs for end openings/joints, being packed appropriately for the climate, and providing protective housing. Before the equipment arrives on site, the foundation on which it will be erected will have been designed and built. Some of the equipment will be installed at site such as field erected tanks. The construction process of the foundation will be coordinated with logistics so that equipment may be set immediately on the foundation as it arrives.

The equipment will be thoroughly checked for any damage or missing pieces due to faulty manufacture or improper transportation. Where any repair work is required, the related procedure will be followed.

**Piping Works**

When a sufficient number of piping material is supplied and design drawings are completed, pre-fabrication of pipes will begin in the fabrication shops. Welding works will be carried out under a controlled atmosphere to improve production efficiency and weld quality. Pipes that have been prefabricated will be welded together and tested after being transported to the assembly site.

The Piping Integrated Management System and physical progress measuring system will be employed together to closely monitor the assembly of interconnecting pipes. The interconnecting and underground piping operations will be accomplished in line with the requirements of the construction schedule. The pressure tests will be scheduled in accordance with the prescribed test phases after the pipe systems have been assembled.

**Electrical and Instrumentation Works**

The use of cable trays will be maximized. The trays will be mounted on top of pipe-carrier poles or as a self-supporting structure.

Field testing of electrical and instrumentation works will include, as a minimum, the following.

- Megger Test
- Continuity testing

Procedures will be established to check, calibrate and maintain inspection, measuring and testing tools (including test software) employed by a subcontractor to check the compliance of electrical and instrumentation devices with engineering specifications for the calibration.

**Lifting/Handling Works**

The works to be carried out for heavy/complex/critical lifting/handling works will include the following:

- Lifting works and selection of handling/lifting equipment, (e.g. cranes, tail lifts, self-driven modular trailers);
- Determining crane locations by considering tail rotation, counterweight, counterweight storage;
- Determining placement locations;

Title:	<i>Chapter 1 - Introduction; Chapter 2 - Regulatory Framework; Chapter 3 - Project Description</i>	Classification:	Internal
DocID:	SC26-OTC-PRJ-EN-REP-000005	Page:	80 of 133
Rev. :	05		



- Assessing the availability of suitable crane (pre-reservation) or other lifting options;
- Engineering controls and verifying heavy/complex cranes (hardware works);
- Assessing the soil bearing pressure for crane pallets and support legs, trailer axle loads, crane counterweights, etc;
- Calculating the distance of the lifting/handling activities from the installed equipment/unit in order to avoid damage to the equipment/units already installed.

**Works at the End of Construction**

Not all sections of the facility will be completed at once. Therefore, some parts and units will be mechanically completed while others will be unfinished. The units with priority, such as power units and safety equipment, will be installed and commissioned earlier than the process units during the facility start-up sequence. Therefore, construction activities will be largely organized by areas, sub-areas, and disciplines, while pre-operational activities will be managed by functional systems.

The functional systems will include the materials, equipment and other subsystems necessary for the operation. The systems will be defined independently from the construction operations to be undertaken. Each system will consist of several subsystems. Each subsystem will be labelled. Material levels will be established, process traceability will be identified, and associated plans will be developed for unlabelled items (such as piping).

The actions to be taken under the pre-operational activities of the onshore production facility are given below.

- Establishing a facility start-up procedure;
- Developing a plan to show space usage of facility;
- Creating facility systematics;
- Verifying the start-up sequence considering the above information;
- Reviewing the plans developed for the pre-operational activities of the facility;
- Reviewing piping and instrumentation schematics (P&IDs), where system inlet, outlet limits are specified and the plant is graphically detailed;
- Establishing the procedure of pre-operational function test for each discipline;
- Reviewing the operation and start-up procedures established for each system;
- Creating a list of audit test reports that must be produced for each system;
- Creating a task record list and a pre-operational activity calendar;
- Creating a list for the services of a seller/supplier under the pre-operational activities of the facility;
- Updating the spare parts, consumables and special tools lists if necessary, during the operation stage;
- Preparing the lists of consumables, such as hoses, oils, coolants, gaskets;

Title:	<i>Chapter 1 - Introduction; Chapter 2 - Regulatory Framework; Chapter 3 - Project Description</i>	Classification:	Internal
DocID:	SC26-OTC-PRJ-EN-REP-000005	Page:	81 of 133
Rev. :	05		

- Updating and detailing the operating and maintenance instructions;
- Holding necessary training with the operating staff;
- Establishing protection procedures;
- Establishing test procedures.

The plans to be developed will include details, definitions, and audit criteria for the sequences of activities to be carried out during the tests and audits. The plans will also include staff responsibilities and control documents of final verification tests to be done under the pre-operational activities.

The facility commissioning procedure to be developed will include details of job descriptions as well as for instructions for final verification testing. The completed activities will be documented and signed by the person who will verify that they have been accomplished. The commissioning procedure will also include a list of necessary drawings. During the verification process, it will be making sure that the drawings utilized are up to date. The manufacturer’s instructions as well as the technical details of the equipment/unit will be checked for each piece of equipment and unit. The list of instructions and technical details necessary for the control will be indicated in the procedure.

All non-conformities and missing items observed during pre-operation activities and commissioning of the facility will be noted and a report for deficiencies will be produced for each subsystem. Actions to be taken to eliminate the identified deficiency or non-conformity will be evaluated. Appropriate actions will be implemented to remedy the deficiency. Further checks to be done will test whether the deficiency has been remedied. If the modifications will affect the subsystems that have already been tested and confirmed to be appropriate, the subsystems will be checked again.

**Completion of the Installation**

The installation will be completed by testing fabrication, installation, and protection techniques in compliance with the specifications, codes, and legal requirements approved for the system/subsystem.

**Pre-Commissioning**

Any part of the facility will be checked, cleaned, dehumidified, and tested at this stage without adding hydrocarbons or auxiliary liquids to the system or permanently energizing these sections. These actions will verify that the installed equipment/components are fully functional.

The pre-commissioning actions will include the following steps.

- Systematic conformity checks of the equipment/components of the facility;
- Static/unenergetic tests on the equipment/components of the facility;
- Washing and cleaning pipelines and tanks;

Pre-commissioning tests will be done on all equipment/components, even if they have been thoroughly tested by the manufacturer.

Title:	<i>Chapter 1 - Introduction; Chapter 2 - Regulatory Framework; Chapter 3 - Project Description</i>	Classification:	Internal
DocID:	SC26-OTC-PRJ-EN-REP-000005	Page:	82 of 133
Rev. :	05		

**Commissioning**

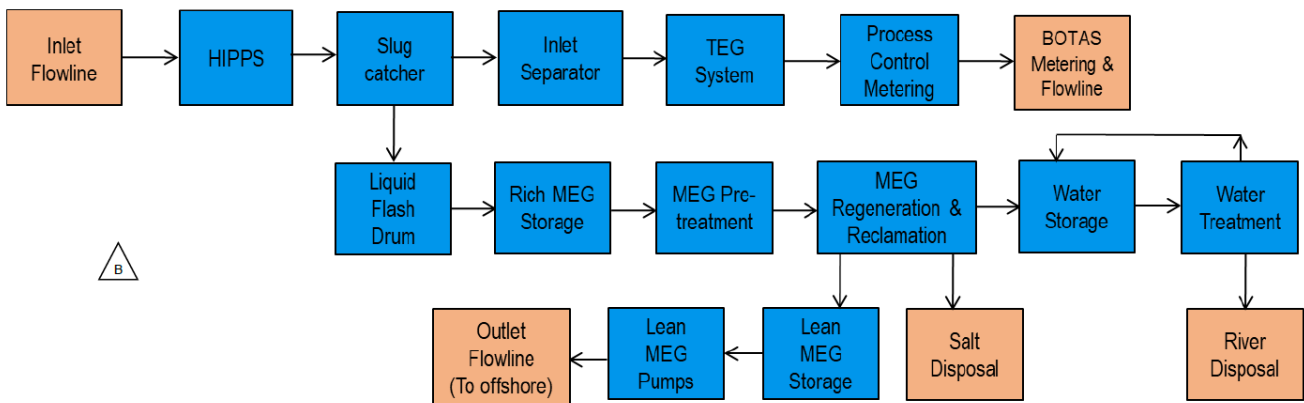
After the pre-commissioning activities, the commissioning process will involve the actions where hydrocarbon and necessary system liquids are introduced into the system. Completion of the commissioning of the system will mean that the system is ready for operation and that the hydrocarbons are introduced into the system and begin to be processed.

The systems in the facility will be commissioned by following the commissioning procedure. This stage attempts to achieve as many pre-operational tests as possible in order to ensure system integrity and performance as designed.

After all commissioning and functional tests have been completed smoothly, the facility will be ready for the operational stage.

**3.4.3 Operation Phase**

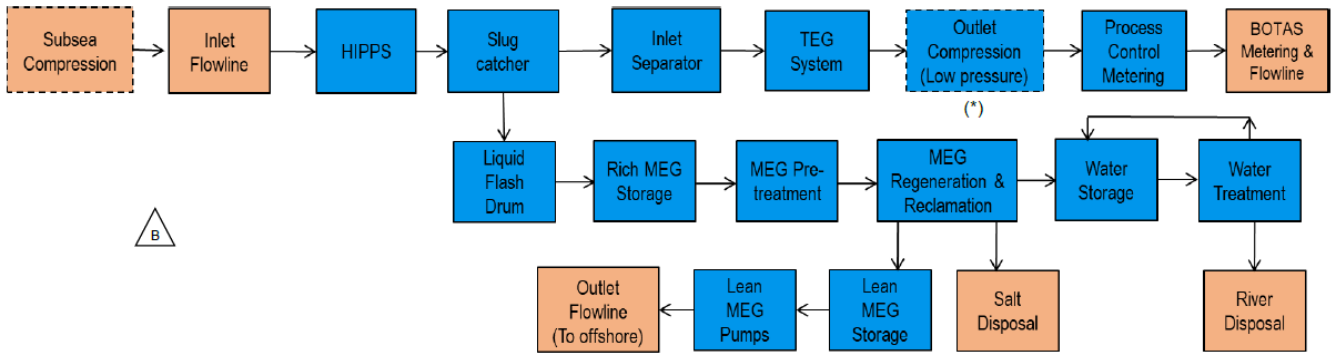
Water and liquids will be separated from the gas flowing from the reservoir, particles will be filtered, the humidity will be absorbed, and gas will be compressed and transported to the network. Figure 3-25 provides the workflow chart of gas processing and liquid processing systems in the OPF.



**Figure 3-25: Workflow Chart of the OPF**

If there is a decline in reservoir pressure, the Phase 1 scheme could evolve to include subsea compression and/or outlet compression as shown in Figure 3-26. The Phase 1 scheme with onshore export compression will be required if the arrival pressure is between 40 barg and 80 barg. This scheme with subsea compression (where no onshore export compression) will be required to maintain the arrival pressure > 80 barg in order to meet the BOTAS requirement.

Title:	Chapter 1 - Introduction; Chapter 2 - Regulatory Framework; Chapter 3 - Project Description	Classification:	Internal
DocID:	SC26-OTC-PRJ-EN-REP-000005	Page:	83 of 133
Rev. :	05		



**Figure 3-26: Workflow Chart of the OPF, Low pressure**

(\*) Onshore Outlet Compression will be required if the inlet flowline arrival pressure is between 40 barg and 80 barg.

**OPF Units**

OPF units (Phase 1) are described below in detail.

Gas Acceptance System

*Inlet, PIG Receivers and High Integrity Pressure Protection System (HIPPS)*

The gas-water-MEG combination that is transported from the subsea production system to the onshore production facility through the gas pipeline will first enter the inflow unit. A receiver mechanism for PIGs to be utilized for pipeline screening will also be included in this unit. The production fluids will bypass the PIG Receiver during normal operations and be fed to downstream process equipment. The operating temperature range in the unit is -7.3 to 24°C, and the operating pressure will be 40-80 barg. This inlet line will have a HIPPS system to protect the downstream piping by reducing the volume of high-pressure gas trapped upstream of the HIPPS if the pressure increases beyond the expected arrival pressures and will allow flexibility in the management of any high-pressure scenario. The unit will be equipped with an emergency shut-off valve and a bypass line.

*Subsea Pressure Protection System*

After the gas-water-MEG combination flows in the facility, its pressure will be adjusted by the subsea pressure protection system and it will be ready for operation. The system will have also been equipped with emergency shut-off valves and a bypass line. This will prevent the liquid pressure from rising to dangerous levels and allow the system to operate safely.

Gas Decomposition System

*Slug Catcher*

The gas-water-MEG combination, with the proper pressure levels adjusted, will flow into a finger-type slug catcher. Slug catcher will accommodate a gas rate of 10 million SCMD and will have a volume of 950 m<sup>3</sup> to handle slugs from Phase 1 pipeline. The gas will be decomposed as much as possible from its water-MEG combination. The pressure and flow meters at the input and outlet of the slug catcher will keep the given parameters under control. The operating temperature range in the unit is -7.3 to 24°C, and the operating pressure will be 40-80 barg. Solids, including reservoir sands and corrosion products from the pipeline are

Title:	Chapter 1 - Introduction; Chapter 2 - Regulatory Framework; Chapter 3 - Project Description	Classification:	Internal
DocID:	SC26-OTC-PRJ-EN-REP-000005	Page:	84 of 133
Rev. :	05		

expected to be produced with the production fluids. These will be carried over from the Slug Catcher to the Liquid Flash Drum where provision for sand jetting/fluidization is provided. The scale inhibitor is injected to prevent scale. The separated gas outlet from the Slug Catcher will be fed to the Inlet Separator via the Indirect Fired Heaters (water bath).

*Indirect Fired Heaters (Water Bath)*

Indirect Fired Heaters, water bath type with fuel gas fired burners, will be provided in the gas stream downstream of the Slug Catchers to raise the fluid temperature to approximately 25 °C when arrival temperatures are very low, below 10 °C, before the gas feed the Inlet Separators. A bypass will be provided for when arrival temperatures are higher, and heating will not be required. Make-up water for the water bath will be provided from the Fresh Water System.

Phase 1 Indirect Fired Heaters will be 2 x 50% and will operate during winter conditions at about 80 barg for the First Gas, and as low as 40 barg in low arrival pressure scenario and receive flow from the Phase 1 Slug Catcher. Heated gas will feed the Inlet Separator.

*Inlet Separators*

Gas will be delivered to two-phase vertical inlet separators after being decomposed from most of the liquid it has contained to decompose the remaining water-MEG combination. The unit will also include levels, temperature and pressure measuring devices, as well as pressure control equipment. There will be a pressure meter in the section where the decomposed gas comes out and a level meter where the decomposed liquid will flow out. Both outlets will contain a compartment for chemical dosing. The operating temperature in the unit is 24°C, and the operating pressure will be 40-80 barg. The liquid outflow line of the inlet separators unit and liquid outflow line of the slug catcher will send it to the liquid flash drum.

The separated gas from the Inlet Separators will feed the corresponding Dehydration System train.

*Gas Dehydration*

The wet saturated gas from the Inlet Separator (Phase 1) feeds the Gas Dehydration System where the gas water content is reduced to meet the sales gas specification. Since the gas dehydration is only required to meet the sales gas dewpoint specification a TEG dehydration system will be utilized.

*Tri-ethylene Glycol (TEG) Dehydration System*

The TEG Dehydration system works on the principle of contacting TEG with the wet process gas and as the TEG has a higher affinity for water vapor, it absorbs the water and reduces the process gas water content. The TEG content, with an increasing amount of water in its content, will be vaporized and dewatered by the gas heated at high temperature under atmospheric pressure. As a consequence, 99% of the TEG will be cleaned up and restored. The outfalls from the TEG system will be routed to a dedicated closed drain system to collect TEG liquids. The recovered TEG will be reutilized after being recovered. The required heating will be powered on at the first phase. There will be additions as needed for TEG, which depletes over time.

*Processing Control Metering*

The gas is transferred to the processing control measurement unit for being measured after being purified of water, MEG, and other components in its content. The pressure and flow rate of the gas will be measured. The gas content will also be checked to ensure that it complies with commercial standards.

Title:	<i>Chapter 1 - Introduction; Chapter 2 - Regulatory Framework; Chapter 3 - Project Description</i>	
DocID:	SC26-OTC-PRJ-EN-REP-000005	Classification: Internal
Rev. :	05	Page: 85 of 133

### Export Gas Compression

The Export Gas Compression is required to boost the pressure to meet the BOTAŞ specification required for the sale gas. This compressor will be required during a low-pressure case.

### Export Gas Pressure Control and Outlet HIPPS

The treated gas will be exported to BOTAŞ via an export pipeline. The minimum pressure of 40 barg to a maximum of 75 barg for the Export Gas will be controlled by a pressure control valve located downstream of the Export Gas Compression on each train. This will allow the final delivery pressure to float with the operating pressure of BOTAŞ as required.

This export line will have a HIPPS system to protect the BOTAS pipeline by reducing the volume of high-pressure gas trapped upstream of the HIPPS if the pressure increases beyond the expected delivery pressure and will allow flexibility in the management of any high-pressure scenario.

Table 3-6 provides the properties of the gas to be processed and exported to the national natural gas transmission network.

**Table 3-6: The Properties of the Gas to be Transported Through Pipeline (BOTAŞ Limits)**

Chemical Composition	Mol Percentage
Methane	Minimum 82%
Ethane	Maximum 12%
Propane	Maximum 4%
Butane	Maximum 2.5%
Pentane and Other Heavy Carbons	Maximum 1%
Carbon Dioxide	Maximum 3%
Oxygen	Maximum 0.5%
Nitrogen	Maximum 5.8%
Hydrogen Sulphur	Maximum 5.35 mg/m <sup>3</sup>
Mercaptan Sulphur	Maximum 16.07 mg/m <sup>3</sup>
Total Sulphur	Maximum 115.50 mg/m <sup>3</sup>
Upper Heating Value	
Maximum	10,427 kcal/ m <sup>3</sup>
Minimum	8,100 kcal/ m <sup>3</sup>
Wobbe Index	
Maximum	13,000 kcal/ m <sup>3</sup>
Minimum	10,465 kcal/ m <sup>3</sup>
Other Properties	

Water Dew Point	Maximum 0°C (Summer Period), -5°C (other periods) (up to 44 Barg)
Hydrocarbon Dew Point	Maximum 0°C (up to 67.5 Barg)
m <sup>3</sup>	15°C and 1.01325 bar corresponds to 1 (one) m <sup>3</sup> of gas volume at absolute pressure.

Source: EIA Report, 2021

**BOTAŞ Fiscal Measurement Station (FMS)**

FMS will be operated by BOTAŞ. In the FMS, natural gas coming from OPF via a 48-inch pipeline flows through 6X20 inch measurement runs after passing through 4 cyclone filters. Each measurement run has an ultrasonic flowmeter and an orifice to measure the natural gas amount and composition. Once measured, the natural gas flows through the Pipeline Inspection Gauge (PIG) station and from there to the pipeline. The FMS will have an administrative building and a backup generator to support in case of a power failure at the FMS.

In addition, there will be 6-inch pipe connections from FMS to OPF for the supply of the first gas from the national grid required for the commissioning phase of the SGFD Project. During the operation phase, gas will be supplied from the FMS to the national grid via a ~36 km 48-inch pipeline that is under construction as of June.

During Phase 1 the pipeline will be connected to the existing take-off station at KP 35+450 and the gas extracted by the Project will be delivered to the national grid with the existing 16-inch pipeline downstream of this station. At this stage, the pipeline between KP 35+450 and KP 36+465 will be constructed and sealed and will not carry gas anymore during Phase 1. In case additional gas will be extracted during Phase 2 of the Project, the connection to the take-off station will be discontinued and a new 48-inch pipeline having an approximately 160 km length will be designed and constructed by BOTAŞ from KP 36+465 on to deliver the gas extracted with the Project to the national grid. Pre-engineering studies for the Phase 2 pipeline continue and the process will be finalized once the engineering studies will be completed. A compressor station may be constructed by BOTAŞ to meet the pressure demand to transmit gas to the natural grid in Phase 2 of the Project.

Liquid Processing System

*Liquid Flash Drums*

The Liquid Flash Drums will be a three-phase horizontal separator, equipped with a Mist Eliminator, an Inlet Vane Device, and Vortex breaker. The separators are equipped with level and pressure transmitters, pressure controller for the gas outlet and level controllers for the liquid outlets. Gas will be flashed off to the LP Flare system by a pressure control valve to maintain the vessel pressure at about 2 barg. In the liquid collection section of the vessel, the liquids separate forming a layer of any produced oil / condensate above the water (produced oil or condensate are not expected but the provision have been provided in case of any minor quantities). This layer will spill over the top of the overflow weir and will be accumulated in this section and intermittently drained to the closed drain vessel as required with level control valve, then will be sent to the Slop Oil Tank where can be truck out. The remaining of the liquid (Rich MEG) in the other side of the overflow weir will be sent to the Rich MEG Storage Tanks by an interface level controller that maintain the layer interface height.

Title:	Chapter 1 - Introduction; Chapter 2 - Regulatory Framework; Chapter 3 - Project Description	
DocID:	SC26-OTC-PRJ-EN-REP-000005	Classification: Internal
Rev. :	05	Page: 87 of 133

Provision for sand jetting/fluidization will be provided for intermittent removal of solids from Liquid Flash Drums carried over from the Slug Catchers. Frequency and duration of sand removal will be determined during operations when sand build up times and amount can be confirmed. This slurry will be sent to the Desander where the solids will be removed and stored on the Sandbag / Bin prior to disposal off-site. This will also be considered in the waste management philosophy.

*MEG Storage Tanks*

Storage tanks will be provided for the rich and lean MEG.

The OPF will have two Rich MEG Tanks and two identical Lean MEG Tanks, blanketed with nitrogen and vented to LLP Flare.

*Rich MEG Storage Tank*

The water-MEG combination that comes out of the liquid flash drums will be stored in the rich MEG storage tanks. Two pumps will transfer the combination contained in the unit to the MEG pre-processing tank. The tanks are sized to accommodate the continue operation for a minimum of 3 days upon failure of one MEG pre-treatment package.

*MEG Pre-Treatment*

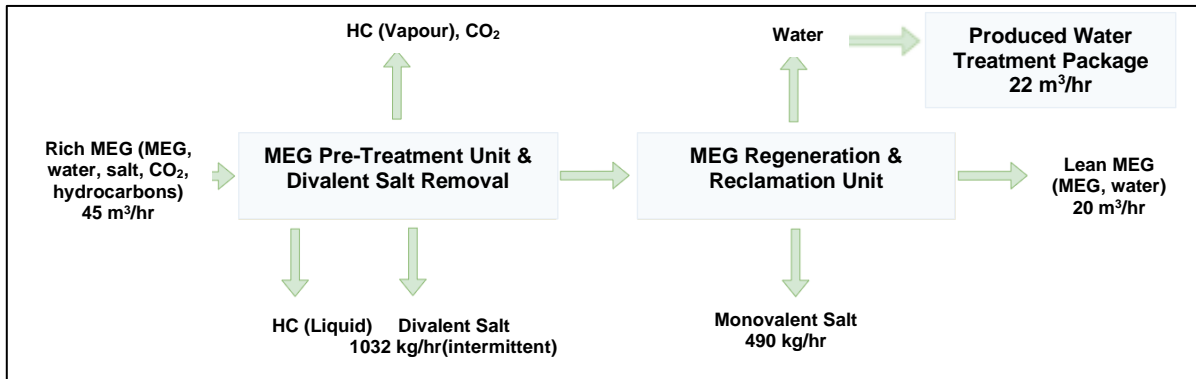
The MEG system will be a full stream reclamation process removing monovalent and divalent salts to low acceptable levels. The rich MEG tank feed the MEG Pre-treatment module. Sodium carbonate, sodium hydroxide, and oxygen absorber are dosed in the MEG pre-treatment unit to adjust the pH of rich MEG and for full crystallization of the divalent salts. The MEG combination will be heated by steam before the dosing. The filtering process will decompose the divalent salts inside the combination. The MEG-enriched combination will be sent to the MEG regeneration and reclamation unit.

*MEG Regeneration and Reclamation Unit*

The MEG regeneration and reclamation unit will be installed as separate systems for each phase and train, sized for 45 m<sup>3</sup>/hr (ultimately) each for a total of four trains. The processed MEG will be transferred to the rich MEG storage unit. In a vacuum atmosphere, the MEG combination in the unit will be vaporized first by steam heat. The monovalent salts contained within its content will not be vaporised but will be decomposed from the MEG and remain as a precipitate in the decomposer chamber. The decomposed precipitate will be centrifuged and the monovalent salts will be decomposed. The vaporized MEG combination will be completely decomposed into industrial wastewater and MEG by being distilled in an air-cooled distillation tower. Decomposed water will be discharge to Filyos River by being treated in an Produced Water Treatment Package and resulting monovalent and divalent salts from the MEG recovery and desalination unit will be sent to appropriate licensed regular waste landfills and disposal sites. The workflow chart of the MEG pre-treatment unit and MEG regeneration & reclamation unit is provided as follows.

Title:	<i>Chapter 1 - Introduction; Chapter 2 - Regulatory Framework; Chapter 3 - Project Description</i>	Classification:	Internal
DocID:	SC26-OTC-PRJ-EN-REP-000005	Page:	88 of 133
Rev. :	05		





**Figure 3-27: Workflow Chart of The MEG Pre-Treatment Unit and MEG Regeneration and Reclamation Unit**

*Lean MEG Storage Tank*

The lean MEG storage tank will be used to store the recovered MEG at the outlet of the MEG Regeneration and Reclamation unit. The tanks store the Lean MEG required by the facility (including subsea system) for hydrate management and is sized to accommodate the continue operation for a minimum of 3 days upon failure of one MEG pre-treatment unit. The recovered MEG will be pumped to the subsea production system and injected in several destination in the onshore facility through the pumps located in the unit.

Produced Water Treatment Package

The water that has been separated by the MEG regeneration and reclamation unit from the MEG will be transferred to the Produced Water Treatment Package Treatment package will be designed to respond to carry over MEG and spikes in methanol concentrations. It will generally be known when this will occur and produced water with MEG / methanol will be sent to the produced water tanks upstream of the treatment unit and will be diluted in line. The treatment technology selected for use will be a Biological Treatment plant

Wastewater will contain minimal quantities of organics e.g., oil MEG, methanol. Wastewater treatment required would reduce trace pollutants and chemical oxygen demand (COD) level...

Wastewater treatment system will have a total capacity of 440 m³/day. Wastewater treated according to Project Standards will be discharged to the Filyos River through a pipe routed to the river running adjacent to the OPF. Re-routing flow back to the system will be available if water samples do not comply with discharge limits.

**The OPF will contain the following components in addition to the main units:**

*Chemical Injection System*

Chemical injection system is provided inside the facility to supply chemicals as required by the wells, subsea infrastructure, and process facilities. Chemicals will be injected both at the subsea wells and within the facility to efficiently process fluids, improve performance and help meet product specifications or protect the equipment and lines from corrosive elements. Chemical storage tanks and injection pumps will be provided where required with tanks sized for 7 days at design injection rates.

The subsea chemicals will be connected to a topside umbilical termination assembly (TUTA). This will provide the interface between the OPF chemical injection systems and the main umbilical supplying the chemicals to

Title:	Chapter 1 - Introduction; Chapter 2 - Regulatory Framework; Chapter 3 - Project Description	Classification:	Internal
DocID:	SC26-OTC-PRJ-EN-REP-000005	Page:	89 of 133
Rev. :	05		

the subsea system. The corrosion inhibitor and Lean MEG will be commingled after discharge from their injection pumps and be injected subsea via MEG injection pipeline. Scale inhibitor will be injected subsea separately via the umbilical.

Scale inhibitor and corrosion inhibitor will also be injected into the OPF process system and will have different compositions from the subsea chemicals. Injection requirements required for the OPF process, utilities and supply to subsea facilities, are displayed below.

**Table 3-7: Chemical Injection Requirements**

Injection Point	Chemical	Mode	Injection Point	Required Flow Rate
SPS	Scale Inhibitor - Offshore	Continuous	Subsea Tree	0.22 m <sup>3</sup> /D (9.16 L/h)
	Corrosion Inhibitor - Offshore	Continuous	MEG Line	0.067 m <sup>3</sup> /D, (2.8 L/h)
	Methanol	Well Start-up	Subsea Tree	24 m <sup>3</sup> /D (1000 L/h)
	MEG	Continuous	Subsea Tree	24.2 m <sup>3</sup> /hr
OPF- Process	Scale Inhibitor - Onshore	Continuous	Upstream Slug catcher or Inlet Separator	0.21 m <sup>3</sup> /D, (8.75 L/h)
	Corrosion Inhibitor - Onshore	Continuous	Upstream Slug catcher or Inlet Separator	0.084 m <sup>3</sup> /D, (3.5 L/h)
	Biocide	Batch	PW Tanks	500 ppm batch/6 hours/week (12 L/D)
	H <sub>2</sub> S Scavenger	Continuous	Gas outlet of Slug catcher	0.3 m <sup>3</sup> /D (4-2 ppm)
	Industrial Wastewater Treatment Chemicals	Continuous or Batch	Industrial Wastewater Treatment	[HOLD]
	MEG	Batch	Upstream control valves and BDV route upstream of HIPPS	15 m <sup>3</sup> /hr to 45m <sup>3</sup> /hr [4]
TEG System	pH Chemical	Batch	TEG Surge Vessel	50 ppm
	Anti-foam	Continuous or Batch	TEG Surge Vessel	Initially at 50 ppm (batch dose) plus continuous at 10

Injection Point	Chemical	Mode	Injection Point	Required Flow Rate
OPF - Utilities	Biocide	Batch	Fresh Water, Potable, Fire Water Tanks	8 m <sup>3</sup> /D (333 L/h)
	Ammonia			0.048 m <sup>3</sup> /D
	Sodium Hydroxide	Continuous	MEG Pre-treatment and Divalent Salt Removal	8 m <sup>3</sup> /D (333 L/h)
	Oxygen Scavenger - MEG	Continuous	MEG Pre-treatment and Divalent Salt Removal. Steam Boiler	0.07 m <sup>3</sup> /D (3 L/h)
	Oxygen Scavenger - Boiler	Continuous	LP Steam Boiler	0.007 m <sup>3</sup> /D (100 ppm)
	Sodium Carbonate	Continuous	MEG Pre-treatment and Divalent Salt Removal	47 m <sup>3</sup> /D (1958 L/h)

Other consumables for the operation phase are given below.

- Diesel is required for Black Start / Emergency Diesel Generator and Fire Water Pumps. Both the Black Start / Emergency Generator and Fire Water Pumps will have their own dedicated diesel day tanks provided by the supplier of the Diesel Generator or Diesel Pump.
- TEG shall be provided (In totes or IBC) with loading pumps to top-up to any TEG lost in the gas dehydration system.
- Precoat material will be used by the MEG Divalent Salt Pre-treatment for the filters. The use of the precoat prevents the filters getting blocks and simplifies the cleaning process. These will be supplied as a solid in approximately 1 tonne bags and will be unloaded as required by the media bag handling system which is part of each of the MEG pre-treatment trains.
- Lube oil systems will be supplied for Export Gas Compressors<sup>8</sup>, Instrument Air Compressors, Inert Gas (Nitrogen) Compressors, Lean MEG Injection Pumps, Steam Turbines within the OPF.

### Fuel Gas System

The fuel gas system will supply fuel gas to units that will use natural gas as a source of energy on-site. The gas scrubber and electric gas heaters will treat the gas that is drawn from the treatment control measurement unit.

<sup>8</sup> No Export Gas Compression is anticipated for Phase 1 as gas pressure from the TEG dehydration system (~77 barg) will be sufficient for meeting the export pressure (40 barg to 75 barg) without the need for compression. However, if there is a decline in reservoir pressure and/or Nitrogen removal is required in Phase 2, Export Gas Compression will be required to meet BOTAS pressure requirement. Separate Residue and Export Gas Compression systems will be installed in Phase 2 along with the NRUs for each train.

Title:	Chapter 1 - Introduction; Chapter 2 - Regulatory Framework; Chapter 3 - Project Description		Classification:	Internal
DocID:	SC26-OTC-PRJ-EN-REP-000005		Page:	91 of 133
Rev. :	05			

The gas scrubber will be electronically controlled. The gas heaters will be equipped with a temperature and flow meter. Fuel gas will be distributed to the following users:

- LP Users (operating pressure around 8 barg):
  - Purge Gas,
  - Pilot gas for flare systems
  - Gas Engines,
  - LP Steam Boiler,
  - Indirect Fired Heaters (water Bath),
  - TEG regenerator stripping gas - optional

*Flare and Vent*

There will be high pressure and low pressure flare systems in the OPF. This is also known as the cold flare ground system. The flare systems will provide a safe and reliable means of collection and disposal of any hydrocarbon released during upset or emergency conditions, operational venting as well as depressurization and venting of a system during maintenance operations.

*Compressed Air Station*

The compressed air system that will be installed in the OPF will supply the necessary instrument air for the devices as well as other needs, some portion of instrument air shall be used to generate N<sub>2</sub> for blanketing and purging purposes There will be a screw compressor, a bed air dryer unit as well as pre-filtration and post-filtration units, N<sub>2</sub> generator. The device air pressure required during the operation will be 4 barg minimum and 7 barg maximum.

*Demineralized and Potable Water Generation Package*

The Demineralized and Potable Water Generation Package will consist of a fresh (raw) water tank and pumps. Fresh water will be supplied through an underground water well by obtaining the necessary permits from the relevant authorities. The pre-treatment section shall comprise of multimedia pressure filters to remove sediments and suspended particles from the raw water followed by ultrafiltration system to achieve final removal of suspended solids and then activated carbon filters to remove residual organic matter as well as chlorine. Ultrafiltrated water shall be stored in a water tank for further supply to reverse osmosis and to firewater tanks. The fresh water will be treated according to specification required for Boiler Feedwater and for the Potable System. The water drawn from groundwater wells will be treated by reverse osmosis.

The system will supply potable water to facility buildings (kitchens, toilets, washbasins, etc.), as well as emergency safety showers and eye showers in production areas.

The demineralized water system, apart from the domestic water system, will process the water which will be drawn from underground wells to supply the water required by the natural gas steam boiler.

The pre-treatment system shall have backwashing and regeneration requirements. Wastewater resulting from backwashing and regeneration of activated carbon filter, multimedia filter and ultrafiltration system will be

Title:	<i>Chapter 1 - Introduction; Chapter 2 - Regulatory Framework; Chapter 3 - Project Description</i>	
DocID:	SC26-OTC-PRJ-EN-REP-000005	Classification: Internal
Rev. :	05	Page: 92 of 133

directed to sedimentation package where the residues and trace heavy metals will be settled and processed in sludge thickener and filter press and finally disposed as per regulations. Resulting wastewater will be discharged to Filyos River.

*Natural Gas Steam Boiler (LP Steam and Heating Medium System)*

The Heating Medium – Process Steam Package will include 2 LP Steam Boilers, Boiler Economizer and Boiler Stack. These fuel gas fired steam boilers will generate dry saturated steam at about 14 barg and 198°C to use as heating medium for the process systems. MEG System will be the major user of the steam as a heating medium in Phase 1. Other users of the steam will include steam heater in the Fuel Gas Package. The steam will be dissipated, and condensate water will be recovered within the process. The collected condensate water and distilled water tank will feed the steam boiler. The steam generated by the heating process will be sent to the necessary equipment, and the condensed steam will be cooled and recovered as water. The thermal power of the steam boiler will be 33.1 MW(t). Additionally, ammonia dosing will keep the pH of the water circulating in the boiler between 9.2 and 9.6. The degassing system will lower the oxygen concentration in the water that will be fed to the boiler to less than 7 ppb before it is sent to the boiler. The water that will be added to compensate for the losses in the boiler will have a conductivity of 0.2 micro siemens and be free of hardness. This will prevent corrosion inside the boiler.

*Electricity Generation System and Connection to the National Electricity Grid*

The amount of electrical energy required for the facility was calculated as 9,000 kW(e) in Phase 1. There will be 3 gas engines (2 in operation and 1 spare) with a capacity of 4,500 kW(e) will be used inside the facility to generate the necessary energy in Phase 1. These engines will burn natural gas to generate electricity. The total thermal power of the 2 gas engines (operational ones) is 18.9 MW(t). Furthermore, the project will be connected to the national electrical grid through a substation (400 kV, with a maximum of 1.3 km connecting lines) on the land side. The national electrical grid will be utilized as a backup power supply when the gas engines are not in use during a maintenance repair. Also, the emergency generators powered by diesel fuel will be available inside the facility. Four diesel generators with their diesel day tank will be supplied in Phase 1 capable of meeting the Phase 1 OPF for black starts and emergency power generation. These will supply power to the main substation, Block 1 substation, and the non process area building station.

*Air Cooling System*

All devices and equipment that will be located in the gas production system will be cooled by air. This system will be linked to every unit that requires cooling.

*Fire Fighting System*

The fire protection strategy of the facility focuses on the prevention and effective response to fire or explosions. This objective shall be achieved primarily by preventing the occurrence of a fire or explosion through the measures taken in advance as well as building an infrastructure for a rapid and effective response when they do occur.

The Firefighting System will consist of two fire water storage tanks, each will be sized to provide a minimum of 6 hours supply based on fire system design case of 4,000 gpm. Each tank having 5,572 m<sup>3</sup> capacity can function independently to supply firewater requirement while the other tank is under maintenance. Each Fire Water Tank will be provided with 3 x 50% diesel driven pumps and 1 x 100% jockey pump (electric motor driver).

Title:	<i>Chapter 1 - Introduction; Chapter 2 - Regulatory Framework; Chapter 3 - Project Description</i>	
DocID:	SC26-OTC-PRJ-EN-REP-000005	Classification: Internal
Rev. :	05	Page: 93 of 133

Auxiliary equipment will include firewater ring main, hydrants, monitors, automatic spray systems, portable and wheeled dry chemical fire extinguishers.

Water supply source is from groundwater wells which will be treated in Demineralized and Potable Water Generation Package before routing to storage tanks. The storage tanks will have an automatic filling system to ensure that it is maintained full. Refill of the water supply after depletion due to a fire shall be completed within 8 hours maximum.

Firewater run-off from process unit paved areas which may be contaminated with liquid hydrocarbons, chemicals or firefighting foam suppressants etc. will be initially contained by means of valve pit to assess contamination levels prior to routing to open drain system. If runoff water is contaminated, this will be routed to ETP-A/slop tank.

*Drainage System*

The drainage systems at the facility include closed and open drains including rainwater collection lines.

- *Closed Drains*

The closed drain system will provide a safe method to collect, recycle or dispose of residual liquids from process vessels, instruments and piping segments. The MEG system will have its own closed drain system for the collection of MEG liquids. The outfalls from the TEG system will be routed to a dedicated closed drain system to collect TEG liquids. The acid degassing system will have its own closed drain system for the collection of solvents (amines). Closed drains will be emptied by vacuum truck and treated by licensed facilities.

- *Open Drains*

The open drain system will collect atmospheric drain liquids from processing area, skid drip-pans, rainwater collection from process areas and vessel open drain connections. The open-drain will be a large underground concrete pit with the depth of which is determined by taking into account the slope of the open drain network, the water table and the distances. Seal pits will be provided strategically in the open drain piping network. The open drain network will be by a combination of gravity flow and from distributed lift stations from the utility sections to minimize the depth of the open drain pits.

The open drains water may contain minimal quantities of organics e.g.: lube oil, diesel, heat transfer oil, MEG, TEG, corrosion inhibitor, and solids, e.g.: sand, corrosion products and salts. There will be two open drain systems, one to collect the open drains from non-hazardous areas to the Non-hazardous Lift Station Pit and liquids will be pumped to the Common Open Drain Pit. The second system is to collect the open drains from hazardous areas to the Hazardous Lift Station Pits and where liquid will also be pumped out to the Common Open Drain Pit. The Common Open Drain Pit will have two compartments. One will be collecting the drains from Hazardous and Non-Hazardous areas and pumped to the Effluent Treatment Plant (ETP-A). The second compartment will collect the drains from the process paved areas and the first flush of 15minutes of contaminated water will be pumped to Effluent Treatment plant (ETP-A) and after 15 minutes the clean water will be diverted to the Filyos River. Stormwater (from open spaces, building’s roof, roadways) shall also be collected in open trapezoidal ditches routed at the sides and parallel to the plant roads. To protect the environment from accidental contaminated water flowing into the river, manually operated sluice gate will be provided before the outfall location of the ditch for examination of stormwater for any contamination.

Title:	<i>Chapter 1 - Introduction; Chapter 2 - Regulatory Framework; Chapter 3 - Project Description</i>	
DocID:	SC26-OTC-PRJ-EN-REP-000005	Classification: Internal
Rev. :	05	Page: 94 of 133

Drains from chemically contaminated paved areas are collected separately in a local concrete sump provided with vacuum truck connection for safe disposal.

A dedicated laboratory drainage system will be provided for wastewaters. Non-hazardous wastewaters from the laboratory will be routed to the open-drain system. Wastewater from the flushing of samples and neutralized solutions shall be collected in a pit outside the Laboratory Building. The sump shall be provided with vacuum truck connection for safe disposal. The wastewaters from sanitary facilities, lodging premises, and kitchens, if any, will not be discharged into the open drain.

All boiler blow down (High TDS Effluents) /hot effluents will be collected on concrete ditches filled with stone pebbles for cooling and routed towards Effluent Treatment Package-A.

*Effluent Treatment Package (ETP-A)*

ETP-A will be installed to treat the potentially contaminated surface runoff water from rainfall and/or firewater from Hazardous and Non-Hazardous areas. This wastewater contains minimal quantities of organics e.g., lube oil, diesel, heat transfer oil, MEG, TEG, corrosion inhibitor and solids (e.g., sand, corrosion products and salts < 150 ppm). Hydrocarbon content in the may be up to 100 ppm of oil. The flow to the ETP-A unit will not be continuous and will be intermittent depending on demand with a flow rate of approximately 90 m<sup>3</sup>/day. After the produced water enters the ETP-A, motor-driven rotors induce a recirculating flow of air or blanket gas into the mixture. This disperses small bubbles throughout the tank volume, and oil droplets and solids are carried to the surface in a rising gas froth, where they are recovered by skimming<sup>9</sup>. Clean water from ETP-A will be routed to Filyos River for discharge. In case ETP-A does not meet river discharge limits, wastewater will be routed to Produced Water Treatment Package. Contaminated skimmed oily wastewater from ETP-A will be removed and routed to the Slop Storage Tank for disposal via vacuum truck.

Sludge, if produced from ETP-A, will be sent to the sludge thickener of the Sanitary Sewage Treatment Package (ETP-B).

*Sanitary Sewage Treatment System (ETP-B)*

A sanitary sewage treatment system (ETP-B) having 75 m<sup>3</sup>/day capacity will be provided to treat the sanitary water collected in the facility and consists of the following units:

- Equalization Tank,
- Primary Settling Tank,
- Biological Treatment (Aeration and Secondary Settling tanks),
- Disinfection Unit (Chlorination Dosing Unit)
- Sludge Storage Tank

The Sludge from ETP-B will be centrifuged and the cake from the centrifuge will be sent for disposal/incineration by others.

<sup>9</sup> <https://www.slb.com/well-production/processing-and-separation/water-treatment/wemco-depurator-unit>

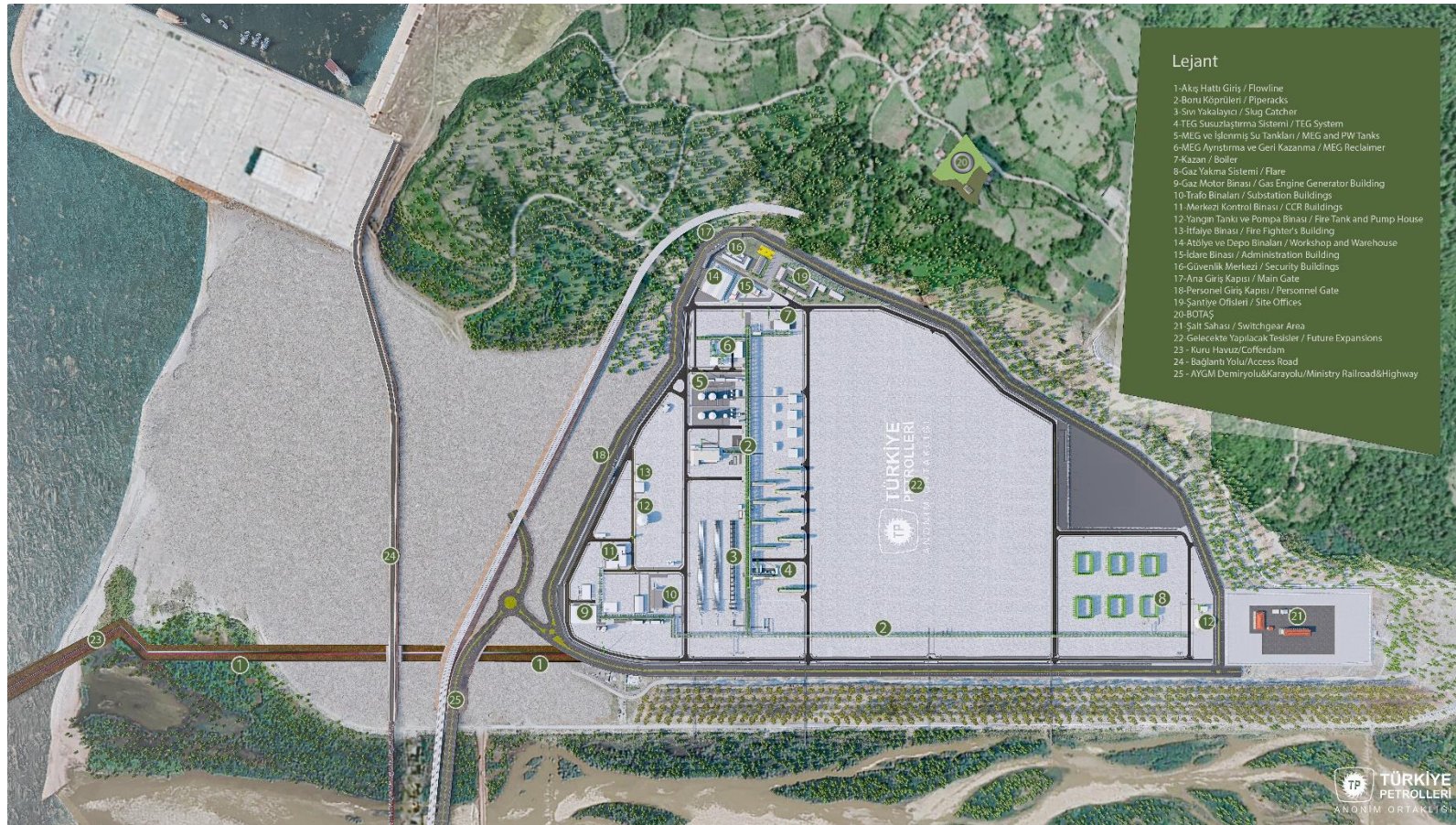
Title:	<i>Chapter 1 - Introduction; Chapter 2 - Regulatory Framework; Chapter 3 - Project Description</i>	
DocID:	SC26-OTC-PRJ-EN-REP-000005	Classification: Internal
Rev. :	05	Page: 95 of 133

Manufacturers will undertake maintenance and repair works, and the controls will be done by considering the technical requirements in the applicable legislation, and records will be kept, and if required, certified.

General Layout of OPF is presented below.

Title:	<i>Chapter 1 - Introduction; Chapter 2 - Regulatory Framework; Chapter 3 - Project Description</i>	Classification:	Internal
DocID:	SC26-OTC-PRJ-EN-REP-000005	Page:	96 of 133
Rev. :	05		





**Figure 3-28: OPF Layout**

## **3.5 Transformer Station and Energy Transmission Line**

### **3.5.1 General Description**

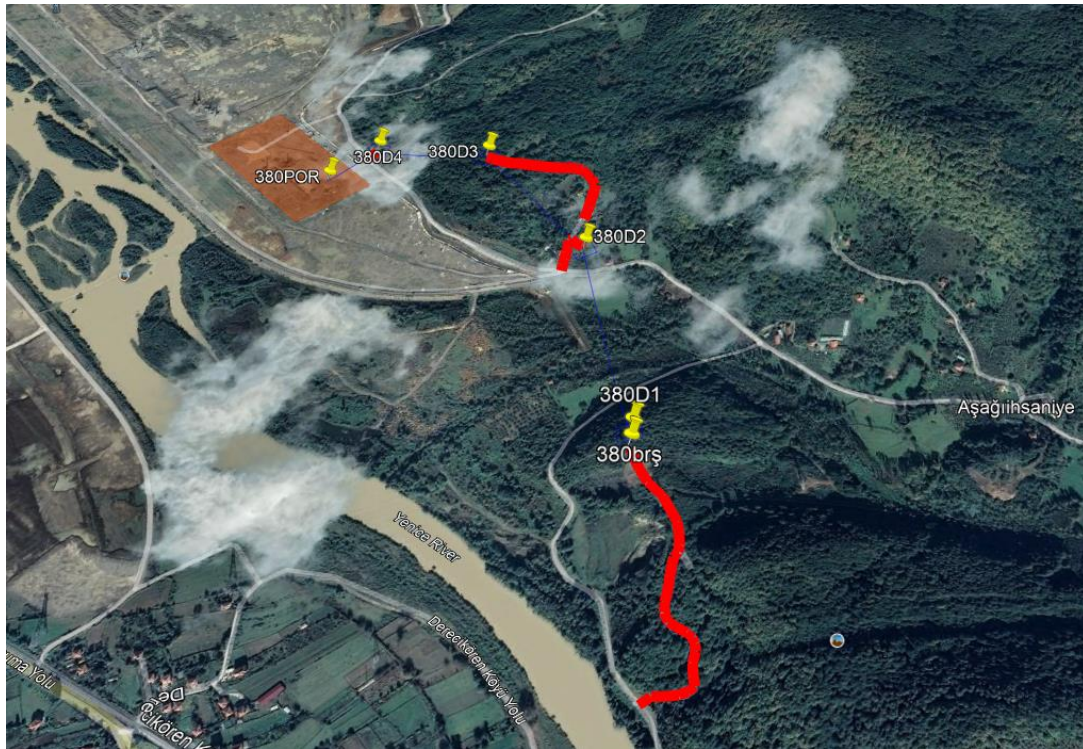
The amount of electrical energy required for the Project was calculated as 9,000 kW(e) in Phase 1. There will be 15kV 3 gas engines (2 in operation and 1 spare) each having a capacity of 4,500 kW(e) will be used inside the facility to generate the necessary energy in Phase 1. These engines will burn natural gas to generate electricity. The total thermal power of the 2 gas engines (operational ones) is 18.9 MW(t). Furthermore, the Project will be connected to the national electrical grid through a substation (with 400 kV Overhead transmission line with a maximum of 1.3 km and GIS Switchyard. Transformer Station includes 400 kV Gas Insulated Switchgears, 400/15kV Transformers, MV Switchgear and related Control System. The Overhead ETL is not covered by the Regulation since it does not meet the limit values for the power transmission line length, indicated in Appendix-1 and Appendix-2 Lists of the “Regulation on Environmental Impact Assessment”, which came into effect through publication on the Official Gazette No. 29186 dated 25.11.2014. The national electrical grid will be utilized as a backup power supply when the gas engines are not in use during a maintenance repair. Also, the emergency generators powered by diesel fuel will be available inside the facility.

### **3.5.2 Construction phase**

Construction activities of the overhead transmission lines can be listed as sub-assembly, top-assembly, wire drawing, testing and commissioning. Within the scope of sub-assembly works, the areas where the pole feet will be placed will be stripped and excavated, and after the preparation of iron bars around the pole feet, concrete pouring will be carried out in molds. Topsoil and subsoil will be stripped and stored separately during this process. Within the scope of the upper assembly works, after the pole feet are placed in the pits, galvanized steel pylons will be mounted to each other with bolts and electricity poles will be constructed. After the assembly works are completed, the wire drawing processes will be completed. Faulty manufacturing, stray voltage, loss of load, etc. in the installed power transmission line. The line will be put into operation after the quality control tests are carried out in order to detect such negativities. Construction works will continue in the corridor with a total width of 50 m, 25 m from the right and left of the route, especially in the areas hit by the poles. Material will be transferred from the site store to the tower location via Hi-ab trucks or any other suitable means. Smaller trucks may be used, for example, where road access is very narrow.

Access roads are required for access of construction vehicles and machinery during construction and for maintenance activities during operation. In this context, existing access roads will be used to reach the route, and it is not planned to open a new road. Access routes are shown in red below.

Title:	<i>Chapter 1 - Introduction; Chapter 2 - Regulatory Framework; Chapter 3 - Project Description</i>	Classification:	Internal
DocID:	SC26-OTC-PRJ-EN-REP-000005	Page:	98 of 133
Rev. :	05		



**Figure 3-29: Satellite Image Showing Access Roads (Red) of Energy Transmission Line (Blue)**

Typical image of the poles is presented below.



**Figure 3-30: Typical Image of Poles**

Title:	Chapter 1 - Introduction; Chapter 2 - Regulatory Framework; Chapter 3 - Project Description	Classification:	Internal
DocID:	SC26-OTC-PRJ-EN-REP-000005	Page:	99 of 133
Rev. :	05		

### 3.5.3 Operation phase

Electricity distribution projects require Rights-of-Way (RoW) to protect the system from windfall, contact with trees, branches, utilities, buildings, and other potential hazards that may result in damage to the system, or power failures, as well as public health and safety concerns. RoWs are also utilised to access, service, and inspect transmission and distribution systems.

According to IFC EHS Guideline for Electric Power Transmission and Distribution, right-of-ways widths for transmission lines range from 15 to 100 m depending on voltage and proximity to other rights-of-way (typical range is between 15 and 30m. Right-of-way width for operation phase will be determined by taking into account IFC EHS Guideline for Electric Power Transmission and Distribution and Regulation on Electric Power Current Facilities (O.G. dated 30.11.2000, numbered 24246).

The Overhead ETL is expected to remain operational throughout the operation period of the OPF which is foreseen as 25-40 years. The operational phase will be mainly limited to maintenance and repair activities for the ETL when needed. These could also include some routine maintenance activities (based on a set schedule) as well as maintenance in case of failure of any of the Project components. Maintenance activities are generally undertaken by a dedicated team of technicians from TEİAŞ and do not normally require any permanent staff to be onsite.

After the ETL is put into operation, agricultural activities can be continued under the wire, and residences and similar structures can be built provided that the approach distances specified in the Regulation on Electric Power Current Facilities are complied.

High Voltage Transformer Station will be operated by Güngör Elektrik during first three years and maintenance will be in the scope of Güngör Elektrik during operation period, if required.

### 3.6 Construction Camp Sites & Permanent Lodgings

It is planned to employ 1,900 people as a maximum for each phase of the construction of the offshore section of the project. Accommodation for the offshore part will be on ships. A maximum of 6,500 people will work during the construction of the Project's onshore section (Phase 1). A large part of the workforce will be accommodated in the construction camps that will be established separately by the contractors. There will be contractor construction camps for Subsea 7, Güngör Elektrik, Schlumberger and their subcontractors and TP-OTC and other authority contractor camp site (existing Kolin camp site) inside the Project boundaries. The Kolin camp site located adjacent to the OPF was established by Kolin for the Filyos Port construction works. The Kolin camp site will continue to be used during the soil improvement works in the scope of the Project. Capacity of each camp is given below.

- Schlumberger and its subcontractors: 2,554 (There may be an additional capacity increase of approximately 2,000 people)
- Kolin: 850
- Subsea7 and its subcontractors: 80
- Güngör Elektrik: 40

Camps will be fully equipped with:

Title:	<i>Chapter 1 - Introduction; Chapter 2 - Regulatory Framework; Chapter 3 - Project Description</i>	
DocID:	SC26-OTC-PRJ-EN-REP-000005	Classification: Internal
Rev. :	05	Page: 100 of 133

The main construction camps will provide at least the following facilities:

- Accommodation with water and electricity supplies
- Office buildings
- Boundary fences/walls with gate, security office and traffic barrier
- Paved roads, hardstanding for lorries and car parking and paved walkways serving all buildings
- Equipment storage and maintenance areas
- Vehicle refuelling and washing facilities
- Toilets and washrooms
- Kitchens and cold storage for food
- Dining rooms
- Laundry
- Medical treatment room
- Recreation facilities
- Offices with telephones, data and postal services
- Diesel generators
- Fuel tanks with secondary containment and a refuelling station
- External lighting to roads and walkways
- Waste accumulation and storage area
- Wastewater treatment plants
- Water treatment units
- Stormwater drainage
- Emergency muster point

Most of the installed housing units will be containerized on pre-installed concrete sleepers and connected to the pre-installed water and sewage lines and electric cabling. All construction camps will be fenced, lighted and guarded. The construction camps will be removed after the construction period. Construction camps position is shown in Figure 3-31.

Title:	<i>Chapter 1 - Introduction; Chapter 2 - Regulatory Framework; Chapter 3 - Project Description</i>	Classification:	Internal
DocID:	SC26-OTC-PRJ-EN-REP-000005	Page:	101 of 133
Rev. :	05		



**Figure 3-31: Construction Camps Positions**

Utilities associated with the camp facilities areas include:

- Power – Diesel generators will be provided to the construction camp for the energy need.
- Water – The drinking water of the personnel will be bottled water. The potable water and any water needed for construction purposes will be supplied from Filyos and Saltukova Municipalities, stored in water tanks and distributed through potable water infrastructure.
- Sewage – Domestic wastewater generated by personnel at the camp site will be collected by sewage infrastructure and treated in package wastewater treatment plants that will be established by contractors and subcontractors exceeding the legal limit (84 people) and the treated wastewater will be discharged to Filyos River and sea during construction phase. Part of the wastewater will be kept in septic tanks and transported to Municipality’s wastewater treatment plant for treatment.
- Drainage – The drainage system within the construction camp and construction facilities area will be designed to collect the runoff water and discharge it into the Filyos River after proper outlet structures to prevent off-site sediment transport.

Title:	Chapter 1 - Introduction; Chapter 2 - Regulatory Framework; Chapter 3 - Project Description	Classification:	Internal
DocID:	SC26-OTC-PRJ-EN-REP-000005	Page:	102 of 133
Rev. :	05		

- Waste disposal area – Temporary waste storage areas are allocated within each camp site for collection, segregation and temporary storage prior to transport offsite.
- Hazardous materials storage – An area will be allocated within each camp site for safe storage of hazardous materials.
- Fuel – Camps will use diesel as fuel for electric generators and construction vehicles and propane, LNG and diesel for boiler system
- Heating – Each camp site has its own heating center and alternatively each room has AC heating. AC heating is used for on-site office containers.
- Medical – There will be infirmaries of each contractor. Also, Health Center established by TPAO at the south entrance of the Project site will be utilised in case of need.

As an example, the layout of Schlumberger camp and offices, which is located in Block 3 of the OPF, is given in Figure 3-32.

In addition, lodgings are planned on an area of 2 hectares, approximately 1.8 km west of the Project area, to be used in the construction and subsequent phases of the Project. The lodgings are planned in 3 blocks Potable water supply will be provided through existing water network. Wastewater will be discharged into existing sewage network of Filyos Municipality which ends with deep sea discharge.

Title:	<i>Chapter 1 - Introduction; Chapter 2 - Regulatory Framework; Chapter 3 - Project Description</i>		
DocID:	SC26-OTC-PRJ-EN-REP-000005	Classification:	Internal
Rev. :	05	Page:	103 of 133

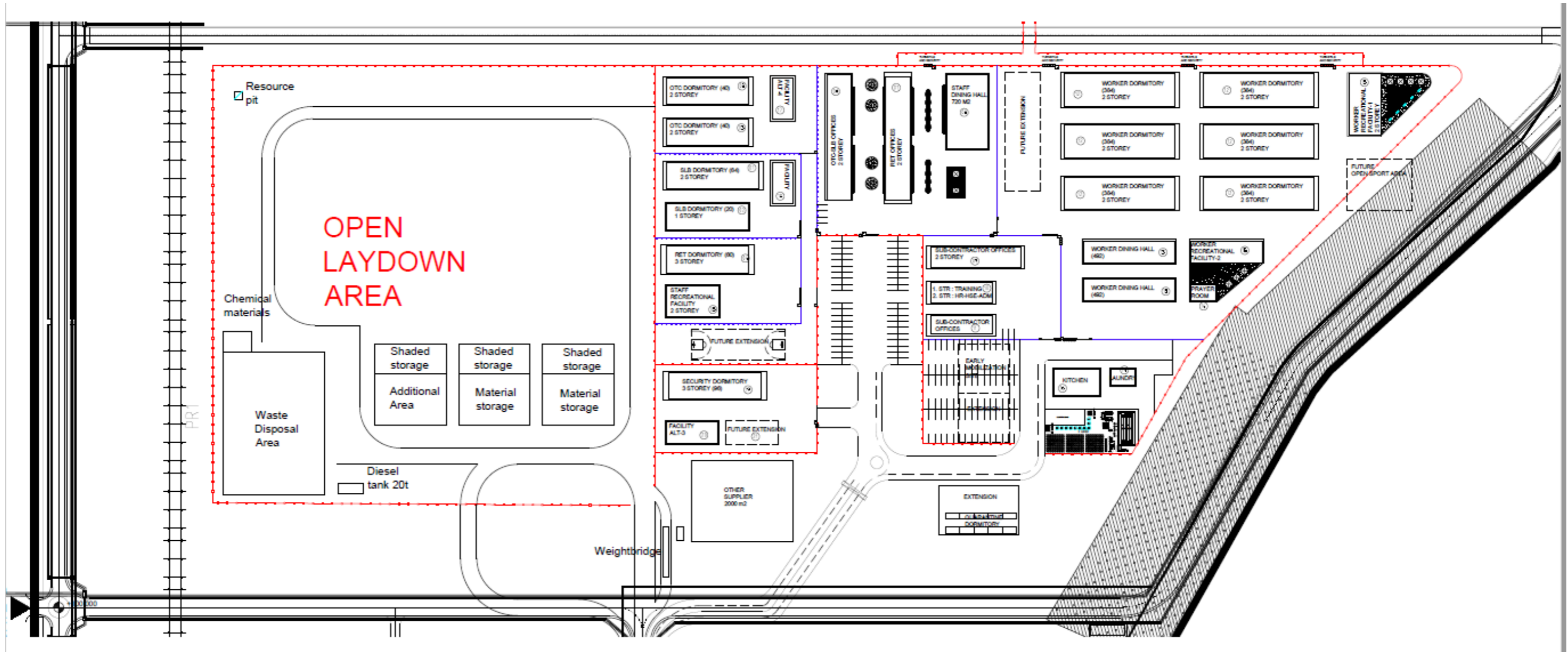


Figure 3-32: Schlumberger Camp&Offices Layout



## 3.7 Resource and Infrastructure Requirements

### 3.7.1 General

#### Waste Management Facilities

The existing licensed waste management infrastructure including landfills and other recycling/recovery facilities in Zonguldak City is given below.

**Table 3-8: Waste Management Facilities in Zonguldak**

Facility Type	Number
Class II Landfill (Municipal Waste and Non-hazardous Waste)	1
Packaging Waste Collection, Separation and Recycling Facilities	5
Packaging Waste Recycling Facilities	3
Hazardous Waste Recovery Facilities	1
Waste Oil Recovery Facility	0
Vegetable Waste Oil Recovery Facility	0
Waste Battery and Accumulator Recovery Facility	0
End-of-life Tire Recovery Facility	0
Medical Waste Sterilisation Facility	1
Non-Hazardous Waste Recovery Facility	9
Waste Electrical and Electronic Equipment Processing Facility	1
Mine Waste Disposal Facility	0
Coastal Waste Receiving Facility*	3
Excavated Soil, Construction and Demolition Waste Storage/Recycling Facility	0

Source: Zonguldak Provincial Environmental Status Report for 2020, 2021

([https://webdosya.csb.gov.tr/db/ced/icerikler/2020\\_zonguldak\\_cdr-20210702095615.pdf](https://webdosya.csb.gov.tr/db/ced/icerikler/2020_zonguldak_cdr-20210702095615.pdf)).

\*There are 3 coastal waste receiving facilities in Zonguldak Province whose are operated by Zonguldak Turkish Hard Coal Enterprise General Directorate, Ereğli Iron and Steel Factories Inc. and Eren Energy Electricity Generation Inc. In addition, BER Environmental Logistics Inc., operating under the port operation of the Zonguldak Turkish Hard Coal Enterprise General Directorate has a waste receiving ship.

#### Wastewater Infrastructure

Urban wastewater management facilities in Zonguldak are listed below.

**Table 3-9: Urban wastewater Management Facilities in Zonguldak**

Settlement	Treatment Facility	Capacity (m <sup>3</sup> /day)
Filyos	Deep sea discharge	1,850
Çaycuma	Wastewater Treatment Plant	3,950

Settlement	Treatment Facility	Capacity (m <sup>3</sup> /day)
Central District	Wastewater Treatment Plant Wastewater Treatment Plant	34,000
Kdz. Ereğli	Wastewater Treatment Plant	59,875.20
Devrek	Wastewater Treatment Plant	8,000
Gülüç	Wastewater Treatment Plant	1,400
Alaplı	Wastewater Treatment Plant	3,924
Nebioğlu	Wastewater Treatment Plant	200

Source: Zonguldak Provincial Environmental Status Report for 2020, 2021  
([https://webdosya.csb.gov.tr/db/ced/icerikler/2020\\_zonguldak\\_cdr-20210702095615.pdf](https://webdosya.csb.gov.tr/db/ced/icerikler/2020_zonguldak_cdr-20210702095615.pdf)).

## 3.7.2 Construction Phase

### 3.7.2.1 Materials

The estimated quantities of the materials considered to be needed in the construction of the offshore section are given in Table 3-10.

**Table 3-10: Offshore Section Construction Materials and Estimated Quantities**

Material	Quantity
Steel (pipe material)	140,000 tons
Coating	18,000 tons
Weld Material	1300 tons
Rock/Stone (for the protection of pipe joints)	9,000 tons
Joint Coating	740 tons

The estimated quantities of the materials that may be needed for the establishment of the cable and pipelines and OPF to be constructed in the onshore section are given in Table 3-11.

**Table 3-11: Onshore Section Construction Materials and Estimated Quantities**

Material	Quantity
<b>Pipeline</b>	
Steel (pipe material)	3 000 tons
Coating	120 tons
Weld Material	40 tons
<b>Onshore Production Facility</b>	
Concrete	35 000 m <sup>3</sup>
Steel	5 500 tons

Title: Chapter 1 - Introduction; Chapter 2 - Regulatory Framework; Chapter 3 - Project Description

DocID: SC26-OTC-PRJ-EN-REP-000005

Rev. : 05

Classification: Internal

Page: 106 of 133

Material	Quantity
Coating	1,200 m <sup>2</sup>
Asphalt/Concrete	14,000 m <sup>3</sup>
Filling Material	52,000 m <sup>3</sup>
UG Pipe (HDPE, DN 200 and DN 500)	20,000 m
Cable	1,100 km
Road Asphalt	55,000 m <sup>2</sup>
Wire/Fence	4,100 x 2 = 8,200 m

The material needed for the construction activities, including bedding, back padding and aggregate will be provided from companies which have permits/licenses in accordance with national regulations.

### 3.7.2.2 Vessels

Information on vessels utilized during construction is presented in Table 3-12 .

**Table 3-12: The Vessels to be Utilized During Construction Phase of Offshore and Coastal Crossing Sections**

Field of Activity	Construction Activity	Vessel Type	Number of Vessels	Duration of Use (days)	Number of Personnel	Desalination Equipment	Power(kW)
Offshore Section	Installation of wellhead valves	DS Fatih	1	365	210	Available	43,200
	Well integration	DS Kanuni	1	365	200	Available	42,000
	Construction of a gas pipeline and a MEG line (all from a water depth of approximately 30 m to the production site and within the site)	PLV CastorONE (or similar)	1	120	702	Available	70,000
	Foundation and installation of distribution chamber as well as the construction of deep-sea umbilical (from approximately 30 km offshore up to the production site and within the site)	HCV-Seven Arctic (or similar)	1	240	132	Available	22,820
	Studies before/after installation, monitoring activities during installation, the	Simar Esperanca (or similar)	1	300	60	Available	8400

Title: *Chapter 1 - Introduction; Chapter 2 - Regulatory Framework; Chapter 3 - Project Description*

DocID: SC26-OTC-PRJ-EN-REP-000005

Rev. : 05

Classification: Internal

Page: 107 of 133

	installation of light equipment for a subsea production system, the connections between subsea equipment, providing support for testing						
	If necessary, seabed interventions along the continental shelf and slope (interventions such as digging underneath the pipe or umbilical to bring them below the seabed level, before or after piping and umbilical laying.)	FFPV Storeness (or similar)	1	120	60	Available	16,572
	Supply of materials, refueling, provisions, water supply	PSV Siem Thiima (or similar)	2	180	12	None	3500
	Crew changes	GSP Lyra (or similar)	1	240	5	None	2,520
	Bilge water and waste water collection	Bryansk (or similar)	1	240	5	None	610
	Pipe supply to the pipe installation vessel	Spliethoff E-tip (or similar)	4	140	16	None	5,430
	Transportation of Distribution Chamber/Subsea lines/ Structures such as piles to Filyos	Cargo Support Ship Boa Barge 32 (or similar)	2	150	0	None	-
	Tugboats for cargo support ships	Boa Odin (or similar)	3	150	15	None	3045
Coastal Crossing Section	Near shore dredging to a depth of 30 m before beginning piping and umbilical laying activities and refilling after installation.	BHD Goliath (or similar)	1	30	20	None	4,336
		TSHD Volvox Delta (or similar)	1	30	25	None	23848
	Investigations before and after installation, and survey and monitoring activities during installation and subsea intervention	C-Worker 7	1	60	0	None	1000

	A barge for towing pipes to shore and then laying gas pipeline and MEG pipeline up to a depth of approximately 30 meters as well as for embedding of pipes up to a depth of approximately 50 meters on the seabed	PLB Castoro 10 (or similar)	1	60	200	None	6900
	Anchoring of the piping ship	Romorkor (Anchor handling tug) Union Manta (or similar )	3	60	15	None	7360
	Laying umbilical in shallow water and then laying umbilical up to 30km open (water depth approx 1900m)	LCV Seven Oceanic (or similar)	1	210	120	Available	36610
		Seven Pacific	1	210	100	Available	2x36610
Waste ships	Waste receiving ship	ÇEVRE KORUMA K 1	1	5	3	N/A	298.28
	Waste receiving ship	BER Ç	1	4	2	N/A	123

The vessels to be used during the construction phase of the Project will operate with diesel fuel. The amount of the fuel needed was calculated as approximately 971 tonnes/day according to Table 3-13 [TBC]. Support vessels will be used for refuelling of ships and waste receipt.

**Table 3-13: Fuel Consumption Calculations of the Vessels to be used during Construction**

Vessel Type	Number of Vessels	Engine Power (kW)	Engine Power (BHP)	K (g/BHP*hour)	Total Fuel Consumption (g/day)	Total Fuel Consumption (tonnes/day)
DS Fatih	1	43,200	57,888	100	138,931,200	139
DS Kanuni	1	42,000	56,280	100	135,072,000	135
PLV CastorONE (or similar)	1	70,000	93,800	100	225,120,000	225
HCV Seven Arctic (or similar)	1	22,820	30,579	100	73,389,120	73
Simar Esperanca (or similar)	1	8,400	11,256	100	27,014,400	27

Vessel Type	Number of Vessels	Engine Power (kW)	Engine Power (BHP)	K (g/BHP*hour)	Total Fuel Consumption (g/day)	Total Fuel Consumption (tonnes/day)
FPV Storeness (or similar)	1	16,572	22,206	100	53,295,552	53
PSV Siem Thiima (or similar)	2	3,500	4,690	100	22,512,000	23
GSP Lyra (or similar)	1	2,520	3,377	100	8,104,320	8
Bryansk (or similar)	1	610	817	100	1,961,760	2
Splithoff E-tip (or similar)	4	5,430	7,276	100	69,851,520	70
Cargo Barc Boa Barc 32 (or similar)	2	0	0	100	0	0
Boa Odin (or similar)	3	3,045	4,080	100	29,378,160	29
BHD Goliath (or similar)	1	4,336	5,810	100	13,944,576	14
TSHD Volvox Delta (or similar)	1	23,848	31,956	100	76,695,168	77
C-Worker 7	1	1,000	1,340	100	3,216,000	3
PLB Castoro 10 (or similar)	1	6,900	9,246	100	22,190,400	22
Union Manta Tow Boat (or similar)	3	7,360	9,862	100	71,009,280	71

### 3.7.2.3 Onshore Equipment

Table 3-14 provides equipment list of each main contractor to be utilized during the land onshore construction phase of the Project as of June 2022 to October 2022.

**Table 3-14: Equipment List (June 2022)**

Equipment	Number
<b>SURF- Landfall Construction</b>	
Dozer Cat	1
Dozer Liebherr	1
Excavator	4
Grader	1
HI-UP	1
Side boom	4
Compressor	2
Generator	2
Generator	4
Truck	2

Equipment	Number
Tractor	1
<b>SURF - Costal Logistics Center</b>	
HI-UP	1
Side boom	4
Generator	2
<b>OPF</b>	
Dump Truck	12
Dozer	1
Grader	1
Excavator 40 ton	1
Excavator 30 ton	1
Tracked excavator 20 ton	1
Tire excavator 20 ton	1
Loader- bucket 20 ton	3
Beko-loader	3
Compactor - roller 16 ton	1
Forklift (10 ton and 2,5 ton)	1
Mini excavator (with crusher)	7
Truck low bed	5
Water tanker 18 ton	3
Water truck	1
Fuel tanker	1
Tractor	3
Generator	19
Light Tower	13
Compressor	5
Compactor -cylinder	3
Compactor -plate	2
<b>Transformer Station &amp; Energy Transmission Line</b>	
Excavator	1
Truck	1
Truck	1
Concrete Mixer	2
Crane	2
Generator (all generators except emergency generators)	2
Wire Pulling and Stopper Machine	1

Title: Chapter 1 - Introduction; Chapter 2 - Regulatory Framework; Chapter 3 - Project Description

DocID: SC26-OTC-PRJ-EN-REP-000005

Rev. : 05

Classification: Internal

Page: 111 of 133

Equipment	Number
<b>Soil Improvement Works</b>	
Bored pile bauer bg 55	1
Bored pile bauer bg 30	1
Bored pile bauer bg 39	1
Bored pile bauer bg 28	1
Bored pile bauer bg 36	1
Bored pile bauer bg 45	1
Crawler crane liebher hs 855	1
Crawler crane texer hc 80	1
Crawler crane sany scc600e	1
Crawler crane texer hc 80	1
Crawler crane liebherr lr 1160	1
Crawler crane xcmg xgc85e	1
Crawler crane sennebogen 3300	1
Crawler crane terex hc 80	1
Crawler crane sany scc900e	1
Crawler crane xcmg quy55e	1
Crawler crane sany scc 500e	1
Excavator sany	1
Excavator komatsu	1
Excavator hidromek 220	1
Loader cat	1
Generator	2
Generator	1
Light tower - generator	6
<b>Concrete Batching Plant</b>	
Concrete Mixer	4
Loader	1
Generator	1

### 3.7.2.4 Infrastructure

#### Electricity

During the construction phase of the Project, it is planned to meet the electricity demand for the activities to be carried out in the onshore section by means of diesel generators. No connection to the local electricity grid is envisaged for the construction phase.

Title:	Chapter 1 - Introduction; Chapter 2 - Regulatory Framework; Chapter 3 - Project Description	Classification:	Internal
DocID:	SC26-OTC-PRJ-EN-REP-000005	Page:	112 of 133
Rev. :	05		



The diesel fuel to be used in the construction phase will be brought to the Project site by road tankers having necessary permissions and licenses. Specific supply areas will be established to supply fuel to the vehicles. These areas will be designed with prevention measures to protect surface waters, ground waters and surface water drainage lines. The diesel fuel brought to the area will be stored inside tanks. Secondary containments having 110% of the fuel capacity of the tanks will be placed under the fuel tanks to store the fuel to prevent spills to the environment.

**Offshore Section – Water Supply and Consumption**

During the construction phase, some vessels will be equipped with desalination equipment to obtain utility water. Support vessels will supply water to the vessels that are not equipped with desalination equipment. Drinking water will be supplied from local vendors in demijohns.

A maximum of 1,900 people will be employed during Phase 1 in the offshore section during the Project construction phase. Water demand per capita is estimated as 228 L/person day based on 2020 data of TUIK (Turkish Statistical Institute) Municipal Water Statistics. As such, the water consumption per day is calculated as follows:

Water demand of the personnel = 1,900 individuals x 228 L/person day = 433,200 L/day = 433.2 m<sup>3</sup>/day

The water consumptions of the vessels that will be used in offshore section during the construction phase are given in Table 3-15.

**Table 3-15: Water Consumption Data for the Vessels to be used in the Offshore Section during the Construction Phase**

Operation Site	Construction	Vessel Type	Number of Vessels	Usage Period (day)	Number of Personnel	Desalination Equipment	Water Demand (m <sup>3</sup> /day)
Offshore Section	Installation of the wellhead valves	DS Fatih	1	365	210	Yes	47.88
	Well integration	DS Kanuni	1	365	200	Yes	45.60
	Construction of a gas pipeline and a MEG line (all from a water depth of approximately 30 m to the production site and within the site)	PLV CastorONE (or similar)	1	120	702	Yes	160.06
	Foundation and installation of distribution chamber as well as the construction of deep-sea umbilical (from approximately 30 km offshore up to the production site and within the site)	HCV-Seven Arctic (or similar)	1	240	132	Yes	30.10

	Studies before/after installation, monitoring activities during installation, the installation of light equipment for a subsea production system, the connections between subsea equipment, providing support for testing	Simar Esperanca (or similar)	1	300	60	Yes	13.68
	If necessary, seabed interventions along the continental shelf and slope (interventions such as digging underneath the pipe or umbilical to bring them below the seabed level, before or after piping and umbilical laying.)	FFPV Storeness (or similar)	1	120	60	Yes	13.68
	Supply of materials, refueling, provisions, water supply	PSV Siem Thiima (or similar)	2	180	12	No	2.74
	Crew changes	GSP Lyra (or similar)	1	240	5	No	15.96
	Bilge water and waste water collection	Bryansk (or similar)	1	240	5	No	1.14
	Pipe supply to the pipe installation vessel	Splithoff E-tip (or similar)	4	140	16	No	3.65
	Transportation of Distribution Chamber/Subsea lines/ Structures such as piles to Filyos	Cargo Support Vessel Boa Barge 32 (or similar)	2	150	0	No	-
	Tugboats for cargo support ships	Boa Odin (or similar)	3	150	15	No	3.42
Coastal Transition Section	Nearshore dredging to a depth of approximately 30 m and post-installation backfilling before starting pipe and cable laying operations.	BHD Goliath (or similar)	1	30	20	No	4.56
		TSHD Volvox Delta (or similar)	1	30	25	No	5.70
	Investigations before and after installation, and survey and monitoring activities	C-Worker 7	1	60	0	No	-

	during installation and subsea intervention							
	barge for towing pipes to shore and then laying gas pipeline and MEG pipeline up to a depth of approximately 30 meters as well as for embedding of pipes up to a depth of approximately 50 meters on the seabed	PLB Castoro 10 (or similar)	1	60	200	No	45.60	
	Anchoring the pipe installation vessel	Romorkor (Anchor handling)	3	60	15	No	3.42	
	Laying umbilical in shallow water and then laying umbilical up to 30km open (water depth approx 1900m)	LCV Seven Oceanic (or similar)	1	210	120	Available	27.36	
		Seven Pacific	1	210	100	Available	22.8	
Waste ships	Waste receiving ship	ÇEVRE KORUMA K 1	1	5	3	N/A	0.684	
	Waste receiving ship	BER Ç	1	4	2	N/A	0.456	
Total								448.49

For pre-commissioning activities of the offshore section of the SURF, pipelines will be filled with seawater. Approximately, 76,285 m<sup>3</sup> seawater will be used. Seawater will be supplied from an intake structure (water winning spread) that will be located at Filyos Port quayside.

### Onshore Section – Water Supply and Consumption

- Potable water needs of the personnel

The personnel who will work in the onshore construction phase will need drinking and utility water. A maximum of 6,500 people will be employed during Phase 1 in the onshore section during the Project construction phase including offsite accommodation and construction camps. Water demand per capita is estimated as 228 L/person day based on 2020 data of TUIK (Turkish Statistical Institute) Municipal Water Statistics. As such, the water consumption per day is calculated as follows:

Water demand of personnel = 6,500 individuals x 228 L/person day = 1,482,000 L/day ≈ 1,482 m<sup>3</sup>/day.

The drinking water of the personnel will be bottled water. The potable water needed for construction purposes and personnel need at the construction camps will be supplied from groundwater wells and Saltukova and Filyos Municipalities by water tankers. As of June 2022, there are 3 potable treatment plants operated by each

contractor to comply with potable water quality standards defined in Appendix C. Potable water needed for the personnel residing in off-site accommodation will be supplied through municipality potable network.

- Water needs for dust suppression during dry periods and fire extinguishing

Any water need for construction purposes will be provided from Saltukova and Filyos Municipalities by water tankers.

- Backwash water need for the potable water treatment plants

The potable water will be supplied by the groundwater wells, after obtaining necessary permissions from the relevant institutions. The raw water will be treated at potable water treatment plants and distributed to the network in the camps. The treatment system shall have backwashing and regeneration requirements of activated carbon filter, multimedia filter and ultrafiltration systems. There are 3 potable water treatments plants operated by each contractor as of June 2022 which requires backwash water of approximately 400 m<sup>3</sup>/day calculated according to 3,524 people of camp capacity. Camp capacity can be increased with the increasing number of people during the peak construction period.

- Make-up water for the concrete production

There will be a need for water in the concrete plant due to concrete production. 0,3 m<sup>3</sup> water will be needed for 1 m<sup>3</sup> of concrete production. Average of daily concrete amount will be approximately 750 m<sup>3</sup>. Total daily water amount is calculated as 225 m<sup>3</sup>/day. Water from plant operation and washing of concrete mixers will be settled in sedimentation ponds and circulated back to the production system. In concrete plants automation systems, the recycling water pump delivers 10% pond water and 90% clean water to the concrete mix.<sup>10</sup> Clean water will be supplied from groundwater wells. Daily make-up water is calculated as 202.5 m<sup>3</sup>/day.

- Pre-commissioning activities

For pre-commissioning activities of the onshore section of the SURF (approximately 1.3 km), pipelines will be filled with groundwater. Approximately, 200 m<sup>3</sup> groundwater will be supplied from wells by tankers.

For pre-commissioning activities of the OPF, 3,500 m<sup>3</sup> groundwater will be supplied from wells by tankers. Indicative water use during the construction phase is summarized below.

**Table 3-16: Indicative Water Use During Construction Phase**

Project activity	Water requirements		
	Water supply source	Water amount	Supply Period
<b>Construction Phase</b>			
Domestic potable water (onshore)	Groundwater Saltukova Municipality Filyos Municipality Offsite accommodation:	Total: 1,482 m <sup>3</sup> /day, calculated according to 6,500 people during peak construction period (the amount includes offsite accommodation)	Throughout the onshore construction

<sup>10</sup> Çiftçi, B., Beyhan, M., 2021. Environmental Risk Assessment in Ready-Mixed Concrete Plants. <https://dergipark.org.tr/en/download/article-file/760475>

Project activity	Water requirements		
	Water supply source	Water amount	Supply Period
	Municipality water network	Camp capacity: 804 m <sup>3</sup> /day (calculated according to 3,524 individuals)	
Domestic potable water (offshore vessels)	N/A	448.9 m <sup>3</sup> /day	Throughout the offshore construction
Dust suppression	Saltukova Municipality	140 m <sup>3</sup> /day	During dry season
Pre-commissioning (Onshore)	Groundwater	3500 m <sup>3</sup>	During onshore pre-commissioning activities Scheduled time : within 5 months
Pre-commissioning (Onshore)	Sea water	76,285 m <sup>3</sup>	During offshore pre-commissioning activities
Concrete production	Groundwater	0.3 m <sup>3</sup> water need for 1 m <sup>3</sup> of concrete Average of daily concrete amount 750 m <sup>3</sup> (approximately) Required daily water amount: 225 m <sup>3</sup> /day The recycling water pump delivers 10% pool water and 90% clean water to the concrete mix Daily make-up water is calculated as 202.5 m <sup>3</sup> /day.	Throughout the concrete production (estimated as May 2022-January 2023)

### Stormwater

The drainage system within the construction camp and construction facilities area will be designed to collect the runoff water and discharge it into the Filyos River after proper outlet structures to prevent off-site sediment transport.

### Traffic

The existing roads will be used in the land preparation and construction phase of the Project and no road widening is planned. In addition, no link road is planned for the construction phase.

The main roads that will be used for supplies during the Construction phase are indicated in the following figures. The connection road (marked with blue in the following figures) starting from Filyos Port, passing through the

Title:	<i>Chapter 1 - Introduction; Chapter 2 - Regulatory Framework; Chapter 3 - Project Description</i>	Classification:	Internal
DocID:	SC26-OTC-PRJ-EN-REP-000005	Page:	117 of 133
Rev. :	05		

area between coastal section of the Project and the OPF, reaching Filyos Industrial Zone and then Filyos town is under construction and will be used within the scope of the Project.

According to Traffic Load Map (2021) published by General Directorate of Highways<sup>11</sup>, the current traffic load on the sections of the Bartın-Çaycuma route, before and after the intersection of Zonguldak Airport which also corresponds to the Project area access road was found to be 5,891 and 8,059, respectively.



**Figure 3-33: Access Roads - Construction**

<sup>11</sup> <https://www.kgm.gov.tr/SiteCollectionDocuments/KGMdocuments/Trafik/trafikhacimharitasi/2021HacimHaritalari/Bolge15.pdf>

Title:	Chapter 1 - Introduction; Chapter 2 - Regulatory Framework; Chapter 3 - Project Description	Classification:	Internal
DocID:	SC26-OTC-PRJ-EN-REP-000005	Page:	118 of 133
Rev. :	05		



**Figure 3-34: Access and Connection Roads – Construction**

The international maritime traffic in the region consists of tankers that transport Caspian and Russian oil to the western markets, as well as other vessels that provide supplies from the sea to and carry out international maritime trade activities for the coastal states on the Eastern Black Sea Region and the Eastern Black Sea Region of Turkey. These vessels navigate in the exclusive economic zone of Turkey at the Black Sea entrance to the Bosphorus, maintaining the breadth of the Turkish territorial waters up to a limit not exceeding 12 nautical miles. This local maritime traffic consists of the Filyos Port and other coastal facilities, such as ports and the fisherman’s shelters in the nearby areas to the east of the port, as well as vessels that navigate to the west or reverse course by passing through the subsea umbilical, connections and pipelines.

Construction vessels and support vessels provided in Chapter 3.7.2.2 will operate in the construction of the SPS and SURF units during the construction phase. In order to ensure safety during construction activities, a safety perimeter of 2 kilometres from right and left side of the umbilical has been established and Navtex announcement was requested to restrict the entrance, anchoring and fishing of third-party vessels between March 07, 2022 and Feb 19, 2023, for 350 days. Letters of notification have been submitted to Ministry of Transport and Infrastructure – Directorate of Maritime Affairs, Ministry of Energy and Natural Resources – Directorate General for External Relations, Ministry of Defence, Ministry of Agriculture and Forestry. Stakeholder consultation activities has been carried out to notify fisherman’s shelters in the vicinity of the Project area.

**3.7.3 Operation Phase**

**3.7.3.1 Materials**

Utilization of any materials other than the materials to be used in the maintenance and repair operations is not expected during the operating phase.

Chemical injection system is provided inside the OPF to supply chemicals as required by the wells, subsea infrastructure, and process facilities. Chemicals will be injected both at the subsea wells and within the facility to efficiently process fluids, improve performance and help meet product specifications or protect the equipment

Title:	<i>Chapter 1 - Introduction; Chapter 2 - Regulatory Framework; Chapter 3 - Project Description</i>	Classification:	Internal
DocID:	SC26-OTC-PRJ-EN-REP-000005	Page:	119 of 133
Rev. :	05		

and lines from corrosive elements. Injection requirements required for the OPF process, utilities and supply to subsea facilities, are presented in Table 3-7.

**3.7.3.2 Vessels**

Although offshore facilities do not require any regular maintenance, vessels may operate in case of need for maintenance/repair during the operation phase.

**3.7.3.3 Onshore Equipment**

Equipment to be kept in the facility during the operation period will be 50 tons crane, 12 tons Diesel forklift, Manlift 10 m height, 5 tons boom truck and 20 tons truck.

The equipment to be used during the operation phase of the Project will operate with diesel fuel. The diesel fuel to be used in the construction phase will be brought to the OPF by road tankers having necessary permissions and licenses and the fuel will be stored in fuel storage tanks.

**3.7.3.4 Infrastructure**

**Electricity**

The amount of electrical energy required for the facility was calculated as 9,000 kW(e) in Phase 1. There will be 3 gas engines (2 in operation and 1 spare) with a capacity of 4,500 kW(e) that will be used inside the facility to generate the necessary energy in Phase 1. These engines will burn natural gas to generate electricity. The total thermal power of the 2 gas engines (operational ones) is 18.9 MW(t). Furthermore, the OPF will be connected to the national electrical grid through a substation (400 kV, with a maximum of 1.3 km connecting line) on the land side. The national electrical grid will be utilized as a backup power supply when the gas engines are not in use during a maintenance repair. Also, the emergency generators powered by diesel fuel will be available inside the facility. Four diesel generators with their diesel day tank will be supplied in Phase 1 capable of meeting the needs for the Phase 1 OPF for black starts and emergency power generation. These will supply power to the main substation, Block 1 substation, and the building area.

The diesel fuel to be needed by the generators to be used under the project will be stored in the fuel storage tanks. To prevent the spread of the fuel spillages, each tank will be designed with a secondary containment.

**Offshore Section – Water Supply and Consumption**

There will be no water consumption from offshore facilities during the operation phase.

**Onshore Section – Water Supply and Consumption**

The units/processes that will need water during the operation phase are listed below.

- Potable water for the personnel;

120 people will be employed during Phase 1. Water demand per capita is estimated as 228 L/person day based on 2020 data of TUIK Municipal Water Statistics. As such, the water consumption per day is calculated as follows:

Maximum water demand of personnel = 120 individuals x 228 L/person day = 27,360 L/day = 27 m<sup>3</sup>/day

- Process water for the Natural Gas Steam Boiler

Title:	<i>Chapter 1 - Introduction; Chapter 2 - Regulatory Framework; Chapter 3 - Project Description</i>	Classification:	Internal
DocID:	SC26-OTC-PRJ-EN-REP-000005	Page:	120 of 133
Rev. :	05		



Natural gas steam boiler will generate dry saturated steam to use as heating medium for process systems. Make-up water required to compensate losses in the boiler is estimated as 15.6 m<sup>3</sup>/day.

- Fire-fighting water

The Firefighting System will consist of two fire water storage tanks, each will be sized to provide a minimum of 6 hours supply based on fire system design case of 4,000 gpm. Each tank has a capacity of 5,572 m<sup>3</sup>. Tanks will be filled with water at the start of the operation phase.

- Backwash water need for the Demineralized and Potable Water Generation Package

The amount of water required for the backwash of filters in the package is 175 m<sup>3</sup>/day.

The potable water, utility water, process water, and fire-fighting water will be supplied by the groundwater well, after obtaining necessary permissions from the relevant institutions. The raw water will be treated at Demineralized and Potable Water Generation Package and distributed to the network. The pre-treatment system shall have backwashing and regeneration requirements of activated carbon filter, multimedia filter and ultrafiltration systems.

Indicative water use during the operation phase is summarized below.

**Table 3-17: Indicative Water Use During Operation Phase**

Project activity	Water requirement		
	Water supply source	Water amount	Supply Period
<b>Operation Phase</b>			
Domestic potable water	Groundwater	27 m <sup>3</sup> /day (calculated according to 120 individuals)	Throughout the operation
Backwash water for Demineralized and Potable Water Generation Package		17 m <sup>3</sup> /h (capacity 175 m <sup>3</sup> /d)	
Boilers		0.65 m <sup>3</sup> /h (15.6 m <sup>3</sup> /day)	
Firewater tanks		N/A	Will be used during emergencies
<b>Total</b>		217.6 (m <sup>3</sup> /day)	

### Stormwater

Open drains network will collect stormwater from the paved areas (open spaces, buildings, roadways, and uncontaminated places) and from ETP-A after treatment and pump into the Filyos River. Stormwater shall also be collected in open trapezoidal ditches routed at the sides and parallel to the plant roads. To protect the environment from accidental contaminated water flowing into the river, manually operated sluice gate will be provided before the outfall location of the ditch for examination of stormwater for any contamination.

### Traffic

The roads to access to the Project site will be the same used during the construction phase.

Title:	<i>Chapter 1 - Introduction; Chapter 2 - Regulatory Framework; Chapter 3 - Project Description</i>	Classification:	Internal
DocID:	SC26-OTC-PRJ-EN-REP-000005	Page:	121 of 133
Rev. :	05		

No major regular load transfer is planned during the operation phase of the Project.

Although offshore facilities do not require any regular maintenance, vessels may operate in case of need for maintenance/repair during the operation phase. In order to ensure safety during maintenance and repair activities, a safety perimeter will be determined and Navtex announcement will be made to restrict third-party vessels entrance to the operation area.

## **3.8 Emission, Wastewater and Waste**

### **3.8.1 Construction Phase**

#### **Emission**

Construction and decommissioning activities may generate emission of fugitive dust caused by a combination of on-site excavation and movement of earth materials, contact of construction machinery with bare soil, and exposure of bare soil and soil piles to wind.

Exhaust gas emissions such as Nitrogen Oxides (NO<sub>x</sub>), Carbon Monoxide (CO), Hydrocarbon (HC), Particulate Matter (PM) and Sulphur dioxide (SO<sub>2</sub>) will occur due to the diesel engines that will be used for electricity generation, construction equipment and vessels that will be operated during the onshore land preparation / construction activities and offshore activities.

During construction and decommissioning activities, noise and vibration may be caused by the operation of pile drivers, earth moving and excavation equipment, concrete mixers, cranes, offshore vessels and the transportation of equipment, materials and people.

#### **Wastewater**

##### Offshore Section

Sources of wastewater to be produced during construction and pre-commissioning works at the offshore section of the Project is listed below:

- Domestic wastewater due to personnel working in vessels;

Water demand of personnel is estimated as 448.9 m<sup>3</sup>/day based on 2020 data of TUIK Municipal Water Statistics. It is assumed that all the domestic water to be used by the Project personnel will be converted to domestic wastewater. As such, the wastewater generation per day is calculated as 448.9 m<sup>3</sup>/day. Domestic wastewater will be taken by waste ships and will be shipped to Zonguldak TTK Waste Receiving Facility for disposal. No wastewater will be discharged into sea.

- Bilge water (leachate and oily wastewater) from machinery spaces in vessels;

Bilge water will be shipped to Zonguldak TTK Waste Receiving Facility for disposal and will not be discharged into sea.

- Ballast and storage displacement water due to water pumped into and out of storage during loading and off-loading operations;

Title:	<i>Chapter 1 - Introduction; Chapter 2 - Regulatory Framework; Chapter 3 - Project Description</i>	Classification:	Internal
DocID:	SC26-OTC-PRJ-EN-REP-000005	Page:	122 of 133
Rev. :	05		

All ships using ballast water exchange will conduct ballast water exchange at least 50 nautical miles (NM) from the nearest land and in water at least 200 m in depth, taking into account Ballast Water Management Convention and Guidelines developed by International Maritime Organization (IMO).

- Wastewater resulting from offshore pre-commissioning activities (typically filtered seawater, or filtered seawater with chemical additives including corrosion inhibitor, oxygen scavenger, biocide, and dye to prevent internal corrosion or to identify leaks, MEG or umbilical transportation liquid).

After the completion of the construction phase and before the pipelines and SPS components are put into operations, all the pipes will be pre-commissioned to detect possible faults in the junctions and prevent leakage. Such test, as described in Chapter 3.2.2 and 3.3.2 for SPS and SURF, respectively. Amount of wastewater resulting from pre-commissioning activities are given below.

**Table 3-18: Discharges related with Pre-commissioning Activities of SPS and SURF**

Discharge Type	Amount (m3)
Filtered Sea Water	49,541
Filtered and Treated Seawater	27,744
MEG	255
Additive (RX 5255 @550 PPM)	15.3
Umbilical Transportation Fluid (MEG/Water Mix 85/15)	266.8
Total	77,822

Resulting wastewater is planned to be discharged deep sea, in correspondence to the SPS site (i.e., at a depth of 2,200 m.

Onshore Section

Sources of wastewater to be produced during construction works at the onshore section of the Project is listed below:

- Domestic wastewater due to personnel working at the onshore section of the Project;

Water demand per capita is estimated as 228 L/person day based on 2020 data of TUIK (Turkish Statistical Institute) Municipal Water Statistics. It is assumed that all the domestic water to be used by the Project personnel will be converted to domestic wastewater. As such, the wastewater generation per day during the peak construction period is calculated as 1,482 m<sup>3</sup>/day including offsite accommodation and construction camps. Domestic wastewater generated by personnel at the camp site will be collected by sewage infrastructure and treated in package wastewater treatment plants that have been established by contractors and subcontractors exceeding the legal limit (84 people). Wastewater collected in septic tanks, or the tanks of the mobile WCs will be transported to the package wastewater treatment plants of the construction camp sites. As of June 2022, there are 3 wastewater treatment plants operated by each contractor. 2 of the plants discharge to Filyos River while 1 of the plant discharges into shoreline of Black Sea. A contractor having personnel number below 84 stores wastewater in septic tanks and transfer to licensed WWTP of the Municipality via vacuum trucks. Until the wastewater treatment plants were commissioned, wastewater was transported to the urban wastewater

Title:	<i>Chapter 1 - Introduction; Chapter 2 - Regulatory Framework; Chapter 3 - Project Description</i>	Classification:	Internal
DocID:	SC26-OTC-PRJ-EN-REP-000005	Page:	123 of 133
Rev. :	05		

treatment plant in Çaycuma District by vacuum trucks. With the commissioning of WWTPs, treated wastewaters will be discharged to the receiving environment in line with the environmental permit to be secured from the Provincial Directorate of Environment, Urbanization and Climate Change as per the Regulation on Environmental Permits and Licenses. WWTP capacities can be increased with the increasing number of people during the peak construction period.

- Wastewater to be produced at the concrete plant due to plant operations and washing of pumps and transmixers

No wastewater will be generated as the settled wastewater is recirculated to concrete production process. In accordance with the Wastewater Treatment/Deep Sea Discharge Plant Project Approval Circular no 2018/14, a Technical Report will be prepared and approved by the competent authorities regarding the usability of this wastewater in the process. In case it is not possible to circulate the wastewater in terms of concrete quality and use it in the process, necessary discharge permit application will be made to the Provincial Directorate of Environment, Urbanization and Climate Change as per the Regulation on Environmental Permits and Licenses and wastewater will be discharged according to the limit values published in Water Pollution Control Regulation.

- Wastewater generated by backwashing of filters in the potable water treatment plants

There are 3 potable water treatments plants operated by each contractor as of June 2022 which generates backwash wastewater of approximately 400 m<sup>3</sup>/day calculated according to 3,524 people of camp capacity. Camp capacity can be increased with the increasing number of people during the peak construction period. Treated wastewaters will be discharged to the receiving environment in line with the environmental permit to be secured from the Provincial Directorate of Environment, Urbanization and Climate Change as per the Regulation on Environmental Permits and Licenses.

- Wastewater resulting from onshore pre-commissioning activities.

Amount of wastewater resulting from pre-commissioning activities at the OPF is estimated to be 3,500 m<sup>3</sup>.

Amount of wastewater resulting from pre-commissioning activities of the onshore part of the SURF (approximately 1,400 m) is estimated to be 200 m<sup>3</sup>.

Summary of the wastewater sources, amounts, treatment methods and discharge locations are given below. Effluent discharge limits are presented in Appendix C.

Title:	<i>Chapter 1 - Introduction; Chapter 2 - Regulatory Framework; Chapter 3 - Project Description</i>	Classification:	Internal
DocID:	SC26-OTC-PRJ-EN-REP-000005	Page:	124 of 133
Rev. :	05		

**Table 3-19: Wastewater to be Generated During the Construction Phase and Management Methods**

Wastewater Source	Wastewater Type	Treatment Package	Daily Amount/Outlet Flowrate	Continuous/ Intermittent	Discharge Location	Discharge Permit*
<b>Construction Phase</b>						
Sewage wastewater (onshore)	Domestic	Biological wastewater treatment plants:	Total: 1,482 m <sup>3</sup> /day, calculated according to 6,500 individuals during peak construction period (the amount) includes offsite accommodation  WWTP Capacity: 540 m <sup>3</sup> /day WWTP capacities can be increased with the increasing number of individuals	Intermittent	Filyos River (Schlumberger-RNS and Subsea7-ACD)	Required
		Kolin (100 m <sup>3</sup> /day for 500 people)			Sea shore (Kolin)	Required
		Schlumberger-RNS (400 m <sup>3</sup> /day for 2000 people)			Transferred to licensed WWTP by vacuum trucks (Güngör Elektrik)	Not required
		Subsea7-ACD (40 m <sup>3</sup> /day for 200 people)			Offsite accommodation-sewage network> licensed WWTPs	Not required
Sewage wastewater (offshore)	Domestic	N/A	448.9 m <sup>3</sup> /day	Intermittent	Shipped by licensed waste barge to the Zonguldak TTK Waste Receiving Facility	Not required
Backwash wastewater from potable water treatment plants	Industrial – includes high TSS (Total suspended solid) may include chloride sulphate and iron, may require pH adjustment	No treatment envisaged, analysis as per Project Standards before discharge is necessary to confirm	400 m <sup>3</sup> /day, calculated according to 3,524 individuals of camp capacity, camp capacity can be increased with the	Intermittent	Filyos River	Required

Title: Chapter 1 - Introduction; Chapter 2 - Regulatory Framework; Chapter 3 - Project Description

DocID: SC26-OTC-PRJ-EN-REP-000005

Rev. : 05

Classification: Internal

Page: 125 of 133

Wastewater Source	Wastewater Type	Treatment Package	Daily Amount/Outlet Flowrate	Continuous/ Intermittent	Discharge Location	Discharge Permit*
			increasing number of individuals			
Wastewater from Pre-commissioning activities (onshore-OPF)	Industrial – High TDS (Total Dissolved Solid), no chemical additives	N/A	3,500 m <sup>3</sup> (total)	Intermittent	Filyos River (by vacuum trucks or open drains) if analysis results are compliant  If not, transferred to licensed WWTPs by vacuum trucks	Not required**
Wastewater from Pre-commissioning activities (onshore-SURF)	Industrial – High TSS and TDS (Total Dissolved Solid), no chemical additives	No treatment envisaged, analysis as per Project Standards before discharge is necessary to confirm	200 m <sup>3</sup> (total)	Intermittent	Filyos River (by vacuum trucks or open drains) if analysis results are compliant  If not, transferred to licensed WWTPs by vacuum trucks	Not required**
Wastewater from Pre-commissioning activities (offshore)	Industrial – High TSS and TDS, include chemical additives, MEG, umbilical transportation liquid	No treatment envisaged, analysis as per Project Standards before deep sea discharge is necessary to confirm	77,822 m <sup>3</sup> (total)	Intermittent	Deep sea (SPS site, at a depth of 2,200 m)	Not required**

\* As per Regulation on Environmental Permits and Licenses.

\*\* It is recommended to obtain opinion of the Ministry/Provincial Directorate of Environment, Urbanization and Climate Change.

## **Waste**

General non-hazardous and hazardous wastes generated due to construction activities are mainly, municipal waste, packaging waste, waste oil, contaminated packaging wastes, hydraulic fluids, used batteries, empty paint and chemical containers, filters, fluorescent tubes, scrap metals and cables, welding waste, end-of-life tires, electrical and electronic wastes, treatment sludge, concrete sludge and medical waste. Significant additional waste stream specific to vessel operations are residues/sludge from scrubbers (exhaust gas cleaning), scrubber systems washing water, incinerator ash (if any), sludge from engine rooms, fuel tanks and/or oil sediments of vessels.

### **3.8.2 Operation Phase**

#### **Emission**

The main sources of air emissions resulting from operations include: combustion emissions from power and heat generation (gas engines and boilers), ground flaring and fugitive emissions (gas/fuel oil leaks). Principal pollutants from these sources include nitrogen oxides, sulfur oxides, carbon monoxide, particulates, volatile organic compounds (VOC), methane and ethane.

During operations, the main sources of noise and vibration pollution will be produced by gas engines and rotating equipment. Noise sources include flares, pumps, compressors, generators, and heaters.

#### **Wastewater**

Sources of wastewater to be produced during the operation phase are listed below

- Domestic wastewater due to personnel

Water demand per capita is estimated as 228 L/person day based on 2020 data of TUIK Municipal Water Statistics. It is assumed that all the domestic water to be used by the Project personnel will be converted to domestic wastewater. As such, the wastewater generation per day is calculated as 27 m<sup>3</sup>/day. A sanitary water treatment system (ETP-B) will be provided to treat the sanitary water collected in the facility. Treated wastewater as per Project Standards will be discharged to Filyos River in line with the environmental permit to be secured from the Provincial Directorate of Environment, Urbanization and Climate Change as per the Regulation on Environmental Permits and Licenses.

- Water that has been decomposed from the MEG by the MEG Regeneration and Reclamation Unit

The water that has been decomposed by the MEG regeneration and reclamation unit from the MEG will be transferred to the Produced Water Treatment Package. Treated wastewater as per Project Standards will be discharged to Filyos River in line with the environmental permit to be secured from the Provincial Directorate of Environment, Urbanization and Climate Change as per the Regulation on Environmental Permits and Licenses.

- Wastewater generated by backwashing of filters in the Demineralized and Potable Water Generation Package;

Wastewater resulting from backwashing and regeneration of activated carbon filter, multimedia filter and ultrafiltration system will be directed to sedimentation package where the residues and trace heavy metals will be settled and processed in sludge thickener and filter press and finally disposed. Resulting wastewater as per Project Standards will be discharged to Filyos River in line with the environmental permit to be secured from the

Title:	<i>Chapter 1 - Introduction; Chapter 2 - Regulatory Framework; Chapter 3 - Project Description</i>	Classification:	Internal
DocID:	SC26-OTC-PRJ-EN-REP-000005	Page:	127 of 133
Rev. :	05		

Provincial Directorate of Environment, Urbanization and Climate Change as per the Regulation on Environmental Permits and Licenses.

- Effluent Treatment Plant-A discharge

This wastewater contains minimal quantities of organics e.g., lube oil, diesel, heat transfer oil, MEG, TEG, corrosion inhibitor and solids (e.g., sand, corrosion products and salts). The flow to the ETP-A unit will not be continuous and will be intermittent depending on demand. Clean water from ETP-A will be routed to Filyos River for discharge in line with the environmental permit to be secured from the Provincial Directorate of Environment, Urbanization and Climate Change as per the Regulation on Environmental Permits and Licenses or Produced Water Treatment Package for further processing. Skimmed oily content will be directed to Slop Storage Tank for disposal via vacuum truck.

- Boiler effluents

All boiler blow down (High TDS Effluents) /hot effluents will be collected on concrete curbed area and routed towards Effluent Treatment Package-A for further processing before discharge into Filyos River.

- Wash water

Any wash water utilized for the internal cleaning of tanks, vessels, and equipment will be disposed to appropriate location depending on contamination i.e., open drain or other appropriate drains with removal facilities using vacuum tanker or other portable vacuum collection system.

Summary of the wastewater sources, amounts, treatment methods and discharge locations are given in below. Technical specifications of the treatment packages are given in Chapter 3.4.3. Effluent discharge limits are presented in Appendix C.

Title:	<i>Chapter 1 - Introduction; Chapter 2 - Regulatory Framework; Chapter 3 - Project Description</i>	Classification:	Internal
DocID:	SC26-OTC-PRJ-EN-REP-000005	Page:	128 of 133
Rev. :	05		



**Table 3-20: Wastewater to be Generated During the Operation Phase and Management Methods**

Wastewater Source	Wastewater Type	Treatment Package	Outlet Flowrate/ Daily Amount	Continuous/ Intermittent	Discharge Location	Discharge Permit
<b>Operation Phase</b>						
Demineralized and Potable Water Generation Package backwash wastewater	Industrial - includes high TSS, may include chloride sulphate and iron, may require pH adjustment	Demineralized and Potable Water Generation Package- Sedimentation Package	17 m <sup>3</sup> /h (capacity 175 m <sup>3</sup> /d)	Intermittent	Filyos River	Required
Open Drains (Oily Water) (Hazardous & Non-Hazardous & Common Drains)	Industrial (stormwater/washwater that may include hydrocarbons)	Effluent Treatment Plant – A  <i>In case ETP-A does not meet river discharge limits, wastewater will be routed to Produced Water Treatment Package for further processing.</i>  <i>Skimmed oily content will be directed to Slop Storage Tank for disposal via vacuum truck.</i>	3.75 m <sup>3</sup> /h (capacity 90 m <sup>3</sup> /d)	Intermittent	Filyos River  Licensed WWTP or waste disposal facility for (skimmed oily content)	Required
Sewage wastewater	Domestic	Effluent Treatment Plant - B	3 m <sup>3</sup> /h (capacity 75 m <sup>3</sup> /day)	Continuous	Filyos River	Required

<b>Wastewater Source</b>	<b>Wastewater Type</b>	<b>Treatment Package</b>	<b>Outlet Flowrate/ Daily Amount</b>	<b>Continuous/ Intermittent</b>	<b>Discharge Location</b>	<b>Discharge Permit</b>
Effluent Wastewater from MEG Reclamation Unit	Industrial - minimal quantities of organics e.g., oil MEG, methanol	Produced Water Treatment Package	22 m <sup>3</sup> /h (capacity 440 m <sup>3</sup> /day)	Continuous	Filyos River	Required
Boiler Effluent (blowdown wastewater)	N/A - High TDS, high temperature Effluent, may require pH control, may include corrosion inhibiting chemicals	Open drain > Effluent Treatment Plant – A	0.65 m <sup>3</sup> /h (15.6 m <sup>3</sup> /day)	Intermittent	Filyos River	Required for ETP-A

**Waste**

Typical non-hazardous and hazardous wastes routinely generated at onshore facilities are general office and packaging wastes, municipal wastes, waste oils, oil contaminated rags, hydraulic fluids, used batteries, empty paint cans, waste chemicals and used chemical containers, used filters, fluorescent tubes, scrap metals and cables, end-of-life tires, electrical and electronic wastes, treatment sludge and medical waste. Significant additional waste stream specific to onshore oil and gas development activities is given below:

- Monovalent salts (sodium, chloride, plus lesser quantities of potassium) and divalent salts (calcium, magnesium, iron, strontium and barium) recovered in the MEG system;
- Slurry removed at Liquid Flash Drums by sand jetting/fluidization;
- Oily water recovered at Liquid Flash Drums;

**3.9 Field Life and Decommissioning**

It is foreseen that the Project will remain in operation for 25-40 years. The operating period of the Project depends on natural gas production in the Sakarya Gas Field and may extend following new explorations. Onshore production facility including all its facilities, equipment and buildings shall have a design life of 25 years. After 25 years, the operational life of the OPF can be extended with the maintenance, repair and revision works. If the production reserve runs out, production feasibility is lost, or the service life of the facility ends, the OPF will need to be removed to enable subsequent land uses. Once the onshore production facility is shut down, all the units will be removed from the site and the rehabilitation operations will commence. If needed, the site grading will be completed, taking into account the surface drainage during operations. The ground surface will be covered according to appropriate vegetation selection (compatible with the soil, climate and flora of the region) after the rehabilitation operations are completed.

Post-operation alternatives are removal of the facility components and restoration of the area or leaving the components as they are in the offshore section. Pipelines left in place will be disconnected and isolated from all potential sources of hydrocarbons; cleaned and purged of hydrocarbons; and sealed at its ends. The two main issues to consider when evaluating these alternatives are risk posing for maritime traffic in the region and environmental impacts. Since no national legislation specifically regulating these areas is available, the General Assembly resolution No. A.672 (16) of the United Nations specialized agency International Maritime Organization (IMO), of which Turkey is a founding member, should be taken into account. This resolution, which is a recommendation to the member states, addresses the alternatives of removing or leaving the marine structures in terms of marine traffic and suggests considering the factors such as the unacceptable risks for humans and the marine environment, use these facilities as an artificial reef for the development of fishing, removal costs, and technical impossibilities in the evaluation. The resolution states that structures at a depth of a minimum of 75 meters and weighing below 4,000 tones can be removed for marine traffic. Since this criterion was intended for offshore platforms, the project does not involve any unit subjected to this limitation.

With reference to the pipelines, although IMO and also other International Conventions (e.g. Kuwait Protocol, 1990; OSPAR Convention, 1992) do not apply directly to the pipelines, it is a consolidated practice to evaluate the situation "case by case" according to some main guidelines:

Title:	<i>Chapter 1 - Introduction; Chapter 2 - Regulatory Framework; Chapter 3 - Project Description</i>	Classification:	Internal
DocID:	SC26-OTC-PRJ-EN-REP-000005	Page:	131 of 133
Rev. :	05		

- For pipelines buried under the seabed a remediation process is generally carried out - for example by cleaning and making them safe from any risks (e.g. chemical contamination or danger to navigation) - and they are then abandoned in situ.
- For the pipelines emerging from the seabed, the possible options of removal (partial or total) or, after a remediation process, sinking (natural or forced) in the sediment, or coverage or mechanical protection can be considered.

In particular, most international guidelines and also national laws of European countries allow abandonment on site if this ensures a lower environmental impact than removal and it does not pose a risk to other uses of the sea.

During the decommissioning phase, operations will be carried out based on the evaluations to be performed considering the technologies, applicable legislation, and the best practices worldwide on that date.

Title:	<i>Chapter 1 - Introduction; Chapter 2 - Regulatory Framework; Chapter 3 - Project Description</i>	Classification:	Internal
DocID:	SC26-OTC-PRJ-EN-REP-000005	Page:	132 of 133
Rev. :	05		

**wsp** **GOLDER**

[golder.com](http://golder.com)